

JUKI®

Super-High-Speed Overlock Machine

High-Speed Overlock Machine / Safety Stitch Machine

MO-6000S series

MO-6900G series (for Extra-heavy-weight Materials)

High-Speed Variable Top Feed Overlock Machine

MO-6900R series

MO-6900J series (for Extra-heavy-weight Materials)

ENGINEER'S MANUAL

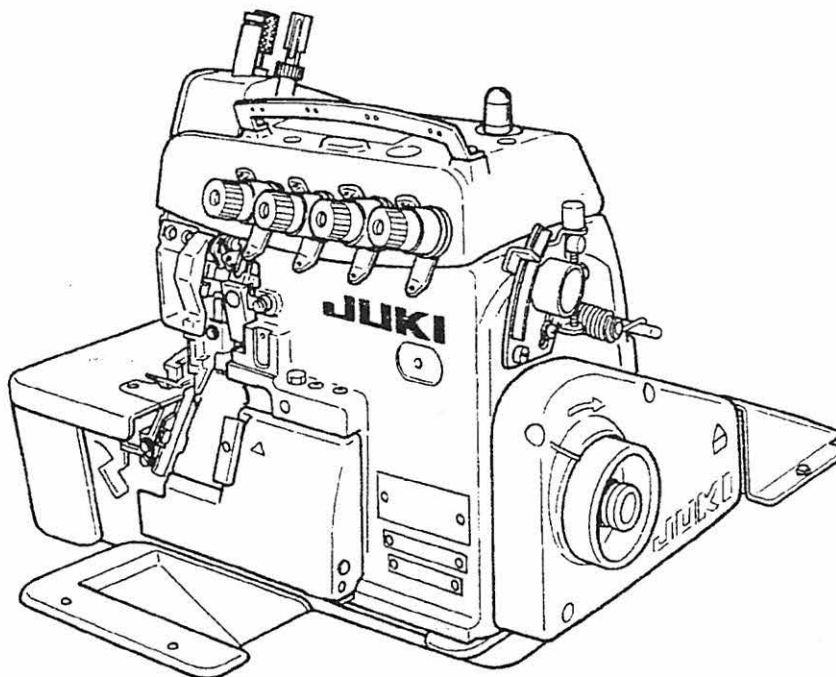

29355807

No.E350-01

PREFACE

This Engineer's Manual is written for the technical personnel who are responsible for the service and maintenance of the machine.

The Instruction Manual for these machines intended for the maintenance personnel and operators at an apparel factory contains operating instructions in detail. And this manual describes "Standard Adjustment", "Adjustment Procedures", "Results of Improper Adjustment", and other important information which are not covered by the Instruction Manual.

It is advisable to use the relevant Instruction Manual and Parts List described below together with this Engineer's Manual when carrying out the maintenance of these machines.

In addition, for the motor for the sewing machine with thread trimmer, refer to the separate Instruction Manual or Engineer's Manual for the motor. And for the control panel, refer to the Instruction Manual for the control panel.

This manual gives the "Standard Adjustment" on the former page under which the most basic adjustment value is described, and on the latter page "Results of Improper Adjustment" under which stitching errors and troubles arising from mechanical failures are described together with the "Adjustment Procedures".

Model	MO-6900S	MO-6700S	MO-6900G	MO-6900R	MO-6900J
Name of part	Part No.	Part No.	Part No.	Part No.	Part No.
Instruction Manual	29351707	29351707	29351707	29356409	29363009
Parts List	29351806	29352408	29352309	29356201	29362803

CONTENTS

1. SPECIFICATIONS	1
(1) MO-6700S SERIES	1
(2) MO-6900S SERIES	2
(3) MO-6900G SERIES	3
(4) MO-6900R SERIES	4
(5) MO-6900J SERIES	5
2. MODEL NUMBERING SYSTEM	6
3. STANDARD ADJUSTMENT	8
(1) Adjusting the needle height	8
(2) Positioning the throat plate	8
(3) Installing position of the needle clamp	10
(4) Adjusting the length of the lower looper holder (Applicable only to MO-6 Δ 16S / MO-6916R, G, J series)	10
(5) Adjusting the lower looper	12
1) Returning amount of the lower looper	12
2) Clearance between the lower looper and the needle	12
(6) Position of the upper looper guide	14
(7) Positioning the upper looper holder	16
(8) Positioning the upper looper	18
1) Height of the upper looper	18
2) Longitudinal position of the upper looper	18
(9) Adjusting the double chain looper (Applicable only to MO-6 Δ 16S/MO-6916R, G, J series)	20
1) Returning amount of the double chain looper	20
2) Longitudinal motion (Avoid motion)	20
3) Clearance between the double chain looper and the needle	20
(10) Adjusting the height and clearance of the needle guard	22
1) For 1-needle or 2-needle overlock machine	22
2) For safely stitch machine	22
(11) Adjusting the height of the feed dog	24
(12) Adjusting the tilt of the feed dog	24
(13) Adjusting the differential feed ratio	26
(14) Longitudinal position of the feed dog	26
(15) Adjusting the presser foot	28
1) Adjusting the tilt of the presser foot	28
2) Adjusting the micro-lifting mechanism of the presser foot	28
(16) Positioning the upper knife arm shaft	30
(17) Positioning the upper and lower knives, and available overedge widths	30
1) Lower knife	30
2) Upper knife	30
3) Overdging width	30
(18) Resharpener of the knife	32
(19) Position of the thread cam (Applicable only to MO-6 Δ 16 Δ series)	32
1) Adjustment of the thread cam	32
2) Adjusting looper thread cam thread guides A and B and the looper thread cam nail	32

(20) Adjusting the throat plate support	34
(21) Adjusting the feed mechanism cover presser	34
(22) Adjusting the looper cover	36
(23) Adjusting the cloth chip cover	36
(24) Adjusting the needle mechanism.....	38
(25) Position of the upper looper lubrication pin	40
1) Orientation of the lubricating pin	40
2) Setting the lubricating pin	40
(26) Longitudinal momentum of the top feed dog (Top feed amount)	42
(27) Vertical momentum of the top feed dog	44
(28) Adjusting the height of the top feed dog	46
(29) Locus cut of the top feed dog	48
(30) Adjusting the longitudinal position of the top feed dog	48
(31) Adjusting the lateral position of the top feed dog	50
(32) Position of the motion of the top feed dog	52
(33) Adjusting the feed bar guides A and B.....	54
(34) Adjusting the top feed dog pressure	56
(35) Lifting amount of the top feed dog (when operating the pedal).....	56
(36) Height of the presser (pedal operation).....	58
(37) Lifting amount of the top feed dog (when the presser lifting lever is operated) ...	60
(38) Position of the thread guides and the looper thread take-ups	62
(39) Adjusting soft chain making mechanism	64
1) Replacing the parts with those exclusively designed for making soft chains	64
2) Adjustment value	64
3) Important points in adjustment	65
(40) Position of the thread guides and the looper thread take-ups of MO-6900G (J) ...	66
4. ADDITIONAL INFORMATION AND PRECAUTIONS	68
(1) Thread tension	68
1) Strength of tension spring	68
2) Springs used for each model.	68
(2) Upper looper	69
(3) Center-to-center distance of the upper looper holder	69
(4) Caution in assembly	69
1) Application of sealant	69
2) Precautions to be taken with respect to the lubricating components	71
(5) Kinds of motor pulleys, belts and frame support plate bolts	72
1) Motor pulleys and belts	72
2) Pat No. of frame support plate bolt	73
(6) Inspection and replacement of the cartridge filter	73
5. ADJUSTMENT OF THE NEEDLE HEIGHT AND LOOPER TIMMING	74
(1) MO-6000△ SERIES	74
6. TROUBLES AND CORRECTIVE MEASURES	75
7. DIMENSIONS OF TABLE	87
(1) Semi-sunken type	87
(2) Fully-sunken type	88

1. SPECIFICATIONS

(1) MO-6700S SERIES

No.	Item	Specifications		
		MO-6704S	MO-6714S	MO-6716S
1	Model	MO-6704S	MO-6714S	MO-6716S
2	Description	1-needle Overlock machine	2-needle Overlock machine	2-needle Safety stitch machine
3	Stitch type F. S. T.	JIS E13 (USA standard : 504)	JIS E24 (USA standard : 514)	JIS E13 + D12 (USA standard : 516)
4	Sewing speed	7,000 rpm		
5	Stitch length	0.8 to 4mm		1.5 to 4 mm
6	Needle gauge	-	2, 2.4, 3.2 mm	2, 3.2, 4, 4.8 mm
7	Overedging width	1.6, 3.2, 4, 4.8 mm	3.2, 4, 4.8 mm	3.2, 4, 4.8, 6.4 mm
8	Differential feed ratio	Gathering 1 : 2 (Max.1 : 4), Stretching 1 : 0.7 (Max.1 : 0.6)		
9	Needle bar stroke	24.5mm		
10	Needle tilt angle	20°		
11	Needle	ORGAN DC X 27 (Standard) (DC X 1 can be used as well.)		
12	Presser lifting amount	7.0 mm	6.5 mm	7.0 mm
13	Presser foot pressure	49N (5Kg)		
14	Stitch adjusting method	By pushbutton		
15	Upper knife	Flat knife		
16	Differential feed adjustment	By lever with micro adjustment mechanism		
17	Weight	28 kg		
18	Lubrication	Gear-type automatic lubrication		
19	Lubricating oil	* JUKI MACHINE OIL 18 (Equivalent to ISO VG 18)		
20	Needle cooler	Optional		
21	Needle thread heat remover	Optional		
22	Micro presser lifting device	Provided as standard		
23	Motor	2P 550W (In case of 7,000 rpm) 2P 400W (in case of less than 7,000 rpm)		

* JUKI MACHINE OIL 18 (Equivalent to ISO VG 18)

Part No. : MML018900CA (900 m ℓ)

(2) MO-6900S SERIES

No.	Item	Specifications		
		MO-6904S	MO-6914S	MO-6916S
1	Model	MO-6904S	MO-6914S	MO-6916S
2	Description	1-needle Overlock machine	2-needle Overlock machine	2-needle Safety stitch machine
3	Stitch type F. S. T.	JIS E13 (USA standard : 504)	JIS E24 (USA standard : 514)	JIS E13 + D12 (USA standard : 516)
4	Sewing speed	8,500 rpm	8,000 rpm	
5	Stitch length	0.8 to 4mm		1.5 to 4 mm
6	Needle gauge	-	2, 2.4, 3.2 mm	2, 3.2, 4, 4.8 mm
7	Overedging width	1.6, 3.2, 4, 4.8 mm	3.2, 4, 4.8 mm	3.2, 4, 4.8, 6.4 mm
8	Differential feed ratio	Gathering 1 : 2 (Max.1 : 4), Stretching 1 : 0.7 (Max.1 : 0.6)		
9	Needle bar stroke	24.5mm		
10	Needle tilt angle	20°		
11	Needle	ORGAN DC X 27 (Standard) (DC X 1 can be used as well.)		
12	Presser lifting amount	7.0 mm	6.5 mm	7.0 mm
13	Presser foot pressure	49N (5Kg)		
14	Stitch adjusting method	By pushbutton		
15	Upper knife	Flat knife		
16	Differential feed adjustment	By lever with micro adjustment mechanism		
17	Weight	28 kg		
18	Lubrication	Gear-type automatic lubrication		
19	Lubricating oil	* JUKI MACHINE OIL 18 (Equivalent to ISO VG 18)		
20	Needle cooler	Provided as standard (Excluding some of subclass machines)		
21	Needle thread heat remover	Provided as standard (Excluding some of subclass machines)		
22	Micro presser lifting device	Provided as standard		
23	Motor	2P 550W (In case of not less than 7,000 rpm) 2P 400W (In case of less than 7,000 rpm)		

* JUKI MACHINE OIL 18 (Equivalent to ISO VG 18)

Part No. : MML018900CA (900 m ℓ)

(3) MO-6900G SERIES

No.	Item	Specifications		
		MO-6904G	MO-6914G	MO-6916G
1	Model	MO-6904G	MO-6914G	MO-6916G
2	Description	1-needle Overlock machine	2-needle Overlock machine	2-needle Safety stitch machine
3	Stitch type F. S. T.	JIS E13 (USA standard : 504)	JIS E24 (USA standard : 514)	JIS E13 + D12 (USA standard : 516)
4	Sewing speed	6,000 rpm		
5	Stitch length	2.5 to 5 mm	2.5 to 4 mm	2.5 to 5 mm
6	Needle gauge	-	2.6 mm	4.8 mm
7	Overedging width	4.8, 10 mm	6.4 mm	4.8, 6.4 mm
8	Differential feed ratio	Gathering 1 : 1.75 (Max.1 : 3.8) Stretching 1 : 0.6	Gathering 1 : 2 (Max.1 : 3.8) Stretching 1 : 0.7 (Max.1 : 0.6)	Gathering 1 : 1.75 (Max.1 : 3.8) Stretching 1 : 0.6
9	Needle bar stroke	28.8 mm		
10	Needle tilt angle	20°		
11	Needle	ORGAN DO X 5		
12	Presser lifting amount	Max. 8 mm		
13	Presser foot pressure	49N (5Kg)		
14	Stitch adjusting method	By pushbutton		
15	Upper knife	Flat knife		
16	Differential feed adjustment	By lever with micro adjustment mechanism		
17	Weight	28 kg		
18	Lubrication	Gear-type automatic lubrication		
19	Lubricating oil	* JUKI MACHINE OIL 18 (Equivalent to ISO VG 18)		
20	Needle cooler	Provided as standard (Excluding some of subclass machines)		
21	Needle thread heat remover	Provided as standard (Excluding some of subclass machines)		
22	Micro presser lifting device	Provided as standard		
23	Motor	2P 400W		

* JUKI MACHINE OIL 18 (Equivalent to ISO VG 18)

Part No. : MML018900CA (900 m l)

(4) MO-6900R SERIES

No.	Item	Specifications		
		MO-6904R	MO-6914R	MO-6916R
1	Model	MO-6904R	MO-6914R	MO-6916R
2	Feed type	Vertical amount of top feed dog		
3	Description	1-needle Overlock machine	2-needle Overlock machine	2-needle Safety stitch machine
4	Stitch type F. S. T.	JIS E13 (USA standard : 504)	JIS E24 (USA standard : 514)	JIS E13 + D12 (USA standard : 516)
5	Sewing speed	7,000 rpm (longitudinal amount of top feed less than 6 mm) 6,000 rpm (longitudinal amount of top feed 6 to 8.5 mm)		
6	Stitch length	0.8 to 4mm		1.5 to 4 mm
7	Needle gauge	-	2 mm	3.2, 4.8 mm
8	Overedging width	3.2, 4, 4.8, 5.6 mm	3.2, 4 mm	3.2, 4, 4.8, 6.4 mm
9	Differential feed ratio	Gathering 1 : 2 (Max.1 : 4), Stretching 1 : 0.7 (Max.1 : 0.6)		
10	Needle bar stroke	24.5mm		
11	Needle tilt angle	20°		
12	Needle	ORGAN DC X 27 (Standard) (DC X 1 can be used as well.)		
13	Presser lifting amount	7.0 mm	6.5 mm	5.5 mm
14	Presser foot pressure	49N (5Kg)		
15	Stitch adjusting method	By pushbutton		
16	Upper knife	Flat knife		
17	Vertical amount of top feed dog	3.5 to 8.5 mm		
18	Longitudinal amount of top feed dog	1 to 7.5 mm (depending on the specifications of the respective machines)		
19	Top feed adjusting type	By lever		
20	Differential feed adjustment	By lever with micro adjustment mechanism		
21	Weight	29 kg		
22	Lubrication	Gear-type automatic lubrication		
23	Lubricating oil	* JUKI MACHINE OIL 18 (Equivalent to ISO VG 18)		
24	Needle cooler	Provided as standard (Excluding some of subclass machines)		
25	Needle thread heat remover	Provided as standard (Excluding some of subclass machines)		
26	Micro presser lifting device	Provided as standard		
27	Motor	2P 550W (In case of not less than 7,000 rpm) 2P 400W (In case of less than 7,000 rpm)		

* JUKI MACHINE OIL 18 (Equivalent to ISO VG 18)

Part No. : MML018900CA (900 m l)

(5) MO-6900J SERIES

No.	Item	Specifications		
		MO-6904J	MO-6914J	MO-6916J
2	Feed type	Vertical amount of top feed dog		
3	Description	1-needle Overlock machine	2-needle Overlock machine	2-needle Safety stitch machine
4	Stitch type F. S. T.	JIS E13 (USA standard : 504)	JIS E24 (USA standard : 514)	JIS E13 + D12 (USA standard : 516)
5	Sewing speed	6,000 rpm		
6	Stitch length	2.5 to 5 mm	2.5 to 4 mm	2.5 to 5 mm
7	Needle gauge	-	2.6 mm	4.8 mm
8	Overedging width	4.8 mm	6.4 mm	4.8, 6.4 mm
9	Differential feed ratio	Gathering 1 : 1.75 (Max.1 : 3.8) Stretching 1 : 0.6	Gathering 1 : 2 (Max.1 : 3.8) Stretching 1 : 0.7 (Max.1 : 0.6)	Gathering 1 : 1.75 (Max.1 : 3.8) Stretching 1 : 0.6
10	Needle bar stroke	28.8mm		
11	Needle tilt angle	20°		
12	Needle	ORGAN DO X 5		
13	Presser lifting amount	Max. 8 mm		
14	Presser foot pressure	49N (5Kg)		
15	Stitch adjusting method	By pushbutton		
16	Upper knife	Square knife		
17	Vertical amount of top feed dog	3.5 to 8.5 mm		
18	Longitudinal amount of top feed dog	2.7 to 7.0 mm (depending on the specifications of the respective machines)		
19	Top feed adjusting type	By lever		
20	Differential feed adjustment	By lever with micro adjustment mechanism		
21	Weight	29 kg		
22	Lubrication	Gear-type automatic lubrication		
23	Lubricating oil	* JUKI MACHINE OIL 18 (Equivalent to ISO VG 18)		
24	Needle cooler	Provided as standard (Excluding some of subclass machines)		
25	Needle thread heat remover	Provided as standard (Excluding some of subclass machines)		
26	Micro presser lifting device	Provided as standard		
27	Motor	2P 400W		

* JUKI MACHINE OIL 18 (Equivalent to ISO VG 18)

Part No. : MML018900CA (900 m l)

2. MODEL NUMBERING SYSTEM

MO-6000 SERIES MODEL NUMBERING SYSTEM

1 2 3 4 5 6 7 8 9 10 11 12 13 14 15 16 17 18 19 20 21 22

MO6 △ △ △ □ □ □ △ △ △ △ / □ △ △ △ - □ □ △

4 Machine code

7	6700 series
9	6900 series

7 Basic specification code

S	Standard
* G	Extra heavy-weight materials
* R	Variable top feed type
* J	Variable top feed type for extra heavy-weight materials

* 6900 only

5.6 Seam code

03	Splicing
04	1-needle 3-thread overlock (504)
05	For blind hemming (505)
12	2-needle 4-thread mock safety stitch (512)
14	2-needle 4-thread overlock (514)
16	2-needle 5-thread safety stitch (516)
43	3-needle 6-thread safety stitch
45	2-needle double chainstitch

8 Needle gauge code

0	1-needle
B	2.0 mm
C	2.4 mm, 2.6 mm (for extra-heavy-weight materials)
D	3.2 mm
E	4.0 mm
F	4.8 mm
1	4.8 mm + 2.0 mm

9 Overedging width code

A	1.6 mm
D	3.2 mm
E	4.0 mm
F	4.8 mm
H	6.4 mm
M	10.0 mm
N	18.0 mm

10 Feed dog code

4	2-row
5	1-row
6	3-row
7	4-row

11 Material code

Classification based on materials to be used		
1	Extra light-weight to light-weight materials	For light-weight materials such as shirts or the like
2	Light-weight to medium-weight materials	Knit wear only
3		General fabrics
4	Medium-weight to heavy-weight materials	Knit wear only such as sweater or the like
5		Medium-weight to heavy-weight materials such as denim or the like
6		For heavy-weight materials
7	Heavy-weight to extra heavy-weight materials	Heavy-weight materials for jeans, car mattress, etc.

12 Application code

Classification based on type of operation and process	
0	Standard
1	For blind stitching
2	For gathering
4	For attaching tape
5	For binding
6	For binding tape
D	Splicing *
E	Car mattress
F	Soft chain

* In case of the splicing, 13th figure is [1].

13 Special machine code

Special classification of machine, structure and specification other than gauge set	
0	Standard
6	Feed dog provided with a lip
7	Upper looper high throw type
F	For swim suits
H	Upper looper extra high throw type
M	For zipper
1	For splicing

15 to 18 Device and attachment code

G02/Q141	Presser foot/tape guide for attaching tape
G39/Q141	Presser foot (for sharp curve)/tape guide for attaching tape
L121	Blind hemming ruler
S159	Swing type ruffler (pedal-interlocking type for safety stitch)
S161	Swing type ruffler (Manual lever type for safety stitch)
S162	Swing type ruffler (Manual lever type for overlock)
N077	Four-fold binder

20 Machine head code

A	Standard machine head (Common to all specifications)
---	---

21 Accessory code

A	For general export *
B	For JE
G	For China

22 Machine head code

0	Fully-sunken type
1	Semi-sunken type

The numberings after "-" (hyphen) of 19th figure will be used on and after April 1, 2002. They are not described on the catalogue or the like.

* The general export specification is for Hong Kong, U.S.A., Japan and Singapore.

3. STANDARD ADJUSTMENT

Standard Adjustment

(1) Adjusting the needle height

When the needle(s) is in the highest position, the needle height from the throat plate surface should be as shown below.

(Unit : mm)

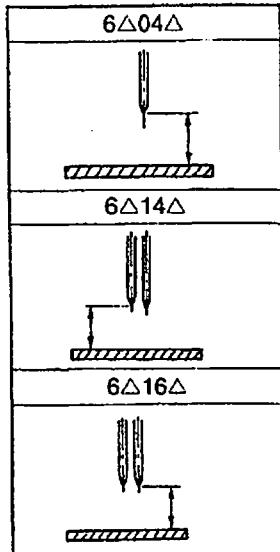

	Model	1-needle/ 2-needle : left	2-needle : right
1-needle overlock machine	MO- 6Δ04S(R) -ΔΔΔ -ΔΔ0	10.5	-
	-ΔΔ6		
	50M		
2-needle overlock machine	MO- 6Δ04S -ΔΔΔ -ΔΔH	11.3	-
	MO- 6Δ05S -ΔΔΔ -ΔΔH	11.3	-
	MO- 6Δ12S -ΔΔΔ -507	11.0	9.4
Safety stitch machine	MO- 6Δ12S -CE4 -40H	11.3	9.9
	MO- 6Δ14S (R) -BΔΔ -3Δ7	10.5	9.1
	MO- 6Δ14S (R) -BΔΔ -20H	11.3	9.9
	-40H		
MO-6900G, J	MO- 6Δ16S(R)-ΔΔΔ -ΔΔ0	10.5	-
	MO- 6Δ16S(R)-ΔΔΔ -ΔΔH	11.3	-
	MO- 6Δ16S(R)-ΔΔΔ -60H	13	-
	MO- 6943R -ΔΔΔ -ΔΔ7	10.5	9.9
	MO- 6Δ43S -ΔΔΔ -ΔΔH	11.3	9.9
	MO- 6Δ45S -ΔΔΔ -360	9.8	-
	MO- 6903G -0N6 -3D1	15.4	-
MO- 6904G(J)-0F6 -700	14.4	-	
MO- 6905G -0M6 -7Δ0	15.4	-	
MO- 6914G(J)-CH6 -700	14.1	12.6	
MO- 6916G(J)-FΔ6 -700	14.1	-	

The adjustment of needle height for the 2-needle overlock machine should be made in reference to the left needle.

(2) Positioning the throat plate

The needle entry point should be such that the distances listed below are provided between the needle slot edge of the throat plate and the center of needle.

Overlock side A	1.3
Double-chainstitch side B	1.0

(Unit : mm)

Note that "A=1.8" and "B=1.5"
for MO-6Δ16S (R) -ΔΔΔ-60H,
"A=1.6" and "B=1.3" for MO-69ΔΔG, J

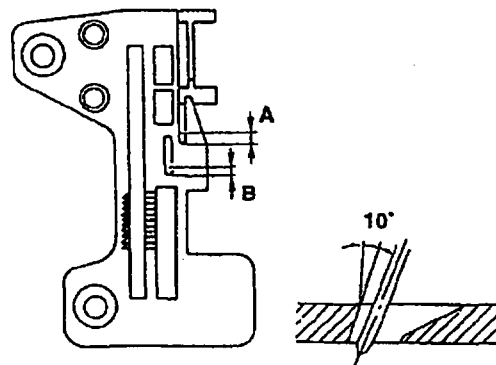

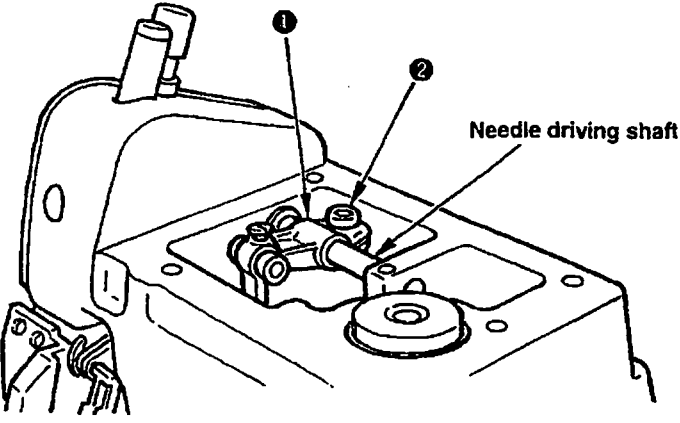
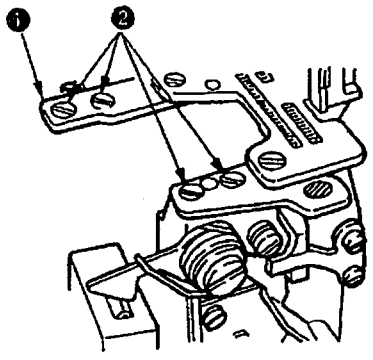
Adjustment Procedures	Results of Improper Adjustment
<p>1) Take off the upper cover, loosen setscrew ② of needle driving forked crank ① and move needle driving forked crank ① up or down to adjust the needle height.</p>  <p>(Caution) Do not fully loosen the setscrew ② of the needle driving forked crank ①. If the needle driving forked crank has got out of position laterally when its setscrew was loosened, fully loosen the setscrew and turn pulley to allow the forked crank to turn until it settles by itself. Then tighten the setscrew to fix the forked crank at that position.</p>	<ul style="list-style-type: none"> ○ Any other needle height than specified here will badly affect the action of the lower looper, the timing for catching the upper looper thread, etc. ○ Improper lateral position of the needle driving forked crank will cause seizure, play, or other troubles.
<p>1) Loosen setscrews ② of throat plate base ① and move throat plate base ① back and forth to adjust dimension A or B.</p> 	<ul style="list-style-type: none"> ○ Improperly positioned throat plate will cause needle breakage, contact of the needles will the throat plate, or other troubles.

Standard Adjustment

(3) Installing position of the needle clamp

Needle clamp connecting stud ① should fit with the bottom end of needle bar ② or spaced within 0 to 0.5 mm.

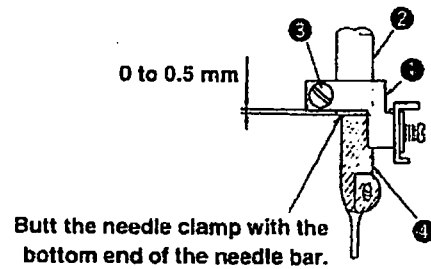

(4) Adjusting the length of the lower looper holder

(Applicable only to MO-6△16S / MO-6916R, G, J series)

The center-to-center distance should be 26 mm.

At this time, the clearance between the end surface of the arm and the neck of the ball should be 3.5 mm.

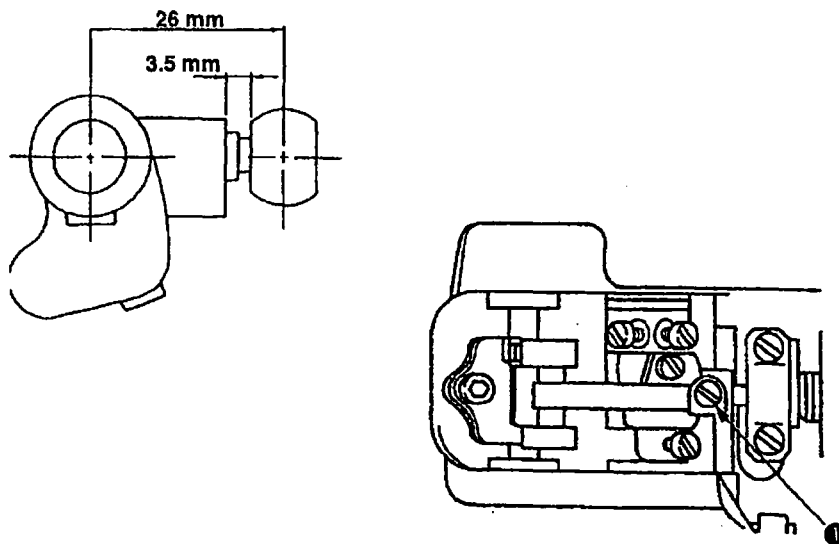

Adjustment Procedures	Results of Improper Adjustment
<p>1) Loosen setscrew ⑤ and adjust, by slightly turning needle clamp ④, the clearance provided between the right-hand side needle and the lower looper (for 2-needle overlock machine) and the clearance provided between the needle hole in the throat plate and the needle (for safety stitch machine).</p>	<ul style="list-style-type: none"> ○ If the clearance provided between the needle and the looper is excessive, the needle thread will be likely to skip at the time of tucking. ○ If the clearance provided between the needle and the looper is insufficient, the needle will break or the looper blade point will be damaged causing thread breakage.
<p>1) Loosen setscrew ① of the lower looper holder from the rear of the frame. Since it is difficult to accurately measure the center-to-center distance, perform adjustment to provide a 3.5 mm distance between the end surface of the arm and the neck of the ball as illustrated.</p>	<ul style="list-style-type: none"> ○ Increasing the center-to-center distance will give a smaller stroke of the double chain looper or lower looper, and decreasing the distance will give larger stroke.

Standard Adjustment

(5) Adjusting the lower looper

1) Returning amount of the lower looper

The distance between the blade point of the lower looper and the center of the needle should be as follows when the lower looper is at the extreme left of its stroke.

(Unit : mm)

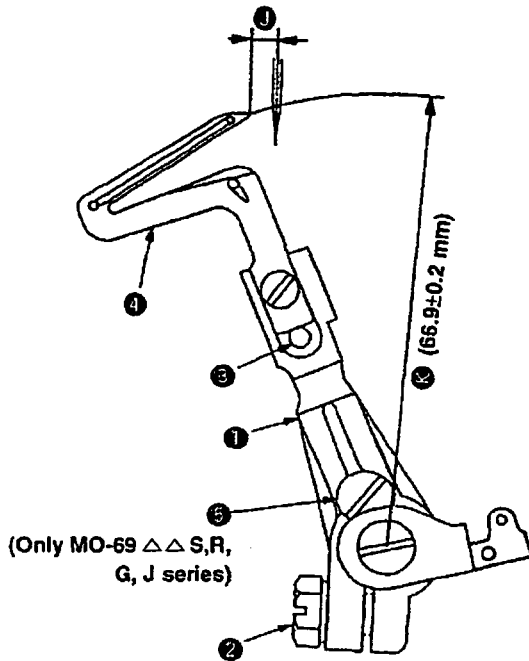

		Model	Dimension ②	
1-needle overlock machine	MO- 6Δ04S(R) 6Δ05S	0A5 15Δ	4.0	
		-0A4 to 0E4 -210		
	MO- 6Δ04S(R)	0D6 3ΔΔ	3.7	
		0F4 3Δ0		
0F6 500				
MO- 6Δ04S	0H4 50M	3.8		
	0D4 to 0E4 4ΔH			
	- 0F6 50H			
2-needle overlock machine	MO- 6Δ14S(R)	BD4 to BE4 -3Δ7	3.8	
		BD6 to BE6		
	MO- 6Δ14S(R)	BD6 to BF6 20H	3.8	
		BE7 4ΔH		
MO- 6Δ12S	-CE4 -40H	4.0		
	-DF6 -50F			
Safety stitch machine	MO- 6Δ16S(R)	-ΔΔΔ 3Δ0	3.7	
		500		
	MO- 6Δ16S(R)	BE4 4ΔH	3.8	
		-DDΔ 5ΔH		
		FΔΔ		
	MO- 6Δ16S(R)	-FΔ6 -50H	2.8	
	MO- 6943R	-ΔΔΔ -ΔΔ7	3.8	
	MO- 6Δ43S	-ΔΔΔ -ΔΔH	3.8	
	MO- 6900G, J	MO- 6903G	-0N6 -3D1	1.4
		MO- 6904G(J)	-0F6 -700	3.5
MO- 6905G		-0M6 -7Δ0	1.3	
MO- 6914G(J)		-CH6 -700	3.3	
	MO- 6916G(J)	-FΔ6 -700	3.5	

2) Clearance between the lower looper and the needle

The clearance should be 0 to 0.1 mm.

0 to 0.1 mm



Adjustment Procedures	Results of Improper Adjustment
<p>1) Returning amount of the lower looper</p> <p>① Loosen setscrew ② of lower looper support arm ① and adjust lower looper ④ to make adjustment of the returning amount.</p> <p>(Referential information)</p> <p>1. Radius ④ of lower looper ④ will be 66.9 mm when the lower looper is inserted into lower looper support arm ① until it contacts with stopper pin ⑤ and then is fixed.</p> <p>2. The rocking angle of the lower looper will be 26°. (MO-6△△△S, R) The rocking angle of the lower looper will be 32°. (MO-69△△G, J)</p>	<ul style="list-style-type: none"> ○ Excessive return of the lower looper tends to cause stitch skipping when filament thread is used. ○ Insufficient return of the lower looper tends to cause needle thread stitch skipping when spun thread is used.
<p>2) Clearance between the lower looper and the needle</p> <p>MO-6700S Series</p> <p>① Loosen setscrew ② of lower looper support arm ① to the extent that it is temporarily tightened. Now, make the adjustment by moving lower looper support arm ① back and forth.</p> <p>MO-6900S, R, G, J Series.</p> <p>① Loosen setscrew ② of lower looper support arm ① to the extent that it is temporarily tightened. Then finely adjust the longitudinal position of the looper using fine adjustment screw ⑤.</p> <p>② Turn fine adjustment screw ⑤ clockwise to move lower looper ④ away from the needle. Turn the screw counterclockwise to move lower looper ④ closer to it.</p>	<ul style="list-style-type: none"> ○ Excessive clearance will often cause needle thread stitch skipping. ○ Insufficient clearance will cause needle breakage due to the contact of the looper with the needle, or produce scratches on the blade point of the looper, leading to needle thread breakage or other troubles.

Standard Adjustment

(6) Position of the upper looper guide

Vertical position :

To be in close contact with the frame guide surface.

Laternal position :

To be pressed against the upper looper guide support gauge ①.

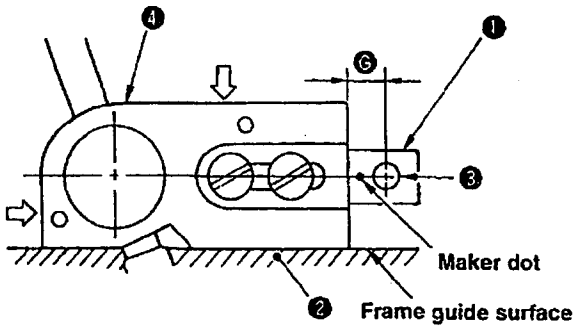

(Unit : mm)

Upper looper guide support gauge		
	13131909	13132006
	11545100	12375606

(Unit : mm)

	Model	Dimension ⑥
1-needle overlock machine	MO- 6Δ04S(R) 0A5 15Δ	
	MO- 6Δ05S -0A4 to 0E4 -210	
	MO- 6Δ04S(R) 0F4 3Δ0	
	MO- 6Δ04S(R) 0H4 -500	
	MO- 6Δ04S 0D4 to 0E4 4ΔH	
	MO- 6Δ04S -0F6 50H	
2-needle overlock machine	MO- 6Δ14S(R) BD4 to BE4 -3Δ7	
	MO- 6Δ14S(R) BD6 to BE6	
	MO- 6Δ14S(R) BD6 to BF6 20H	
	MO- 6Δ14S(R) BE7 4ΔH	
	MO- 6Δ12S -CE4 -40H	
	MO- 6Δ12S -DF6 507	
	MO- 6Δ12S -50F	

(Unit : mm)

	Model	Dimension ⑥
Safety stitch machine	MO- 6Δ16S(R) -ΔΔΔ 3Δ0	
	MO- 6Δ16S(R) BE4 -4ΔH	
	MO- 6Δ16S(R) -DDΔ 50H	
	MO- 6Δ16S(R) -FΔΔ	
	MO- 6Δ16S(R) -FΔ6 -60H	
	MO- 6943R -ΔΔΔ -ΔΔ7	
MO-6900G, J	MO- 6Δ43S -ΔΔΔ -ΔΔH	
	MO- 6903G -0N6 -3D1	
	MO- 6904G(J) -0F6 -700	
	MO- 6905G -0M6 -7Δ0	
	MO- 6914G(J) -CH6 -700	
	MO- 6916G(J) -FΔ6 -700	

Adjustment Procedures	Results of Improper Adjustment
<p>1) Fit upper looper guide support gauge ① over gauge fixing pin ③ which has been driven in frame ② and secure the gauge with an O ring. Then position the gauge taking the marker dot engraved on it or the chamfering direction as reference.</p> <p>2) When installin upper looper guide support ④, press it against the gauge while keeping the upper looper guide support into close contact with the frame guide surface, then tighten the screws.</p> <p>(Caution) Refer to “4- (4) -1) - ⑦ Various sealants” for the various sealants.</p>	<ul style="list-style-type: none"> ○ If the upper looper guide has improperly positioned vertically, it will cause oil leakage or disturbed path of the upper looper with resultant stitch skipping. ○ If the upper looper guide has been inaccurately positioned laterally, it will cause stitch skipping, or contact with the looper.

Standard Adjustment

(7) Positioning the upper looper holder

The distance between the bottom surface of the frame and the upper end of the upper looper holder pin ② should be as shown below when the upper looper holder ① is at the highest point of its stroke.

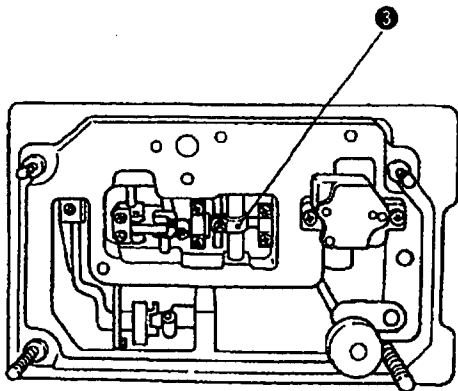
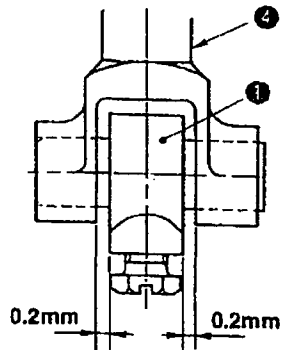
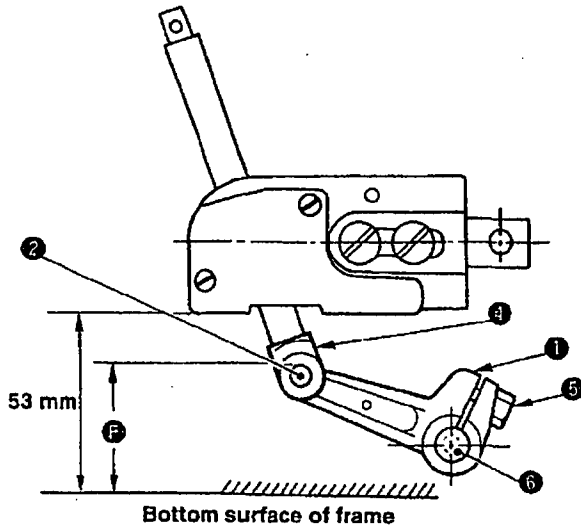

(Unit : mm)

		Model	Dimension (F)
1-needle overlock machine	MO- 6Δ04S(R) 6Δ05S	0A5 15Δ	45.0
		-0A4 to 0E4 -210	
		0D6 3ΔΔ	
	MO- 6Δ04S(R)	0F4 3Δ0	46.2
		0F6 -500	
	MO- 6Δ04S	0H4 50M	
0D4 to 0E4 4ΔH		48.2	
- 0F6 -		50H	
2-needle overlock machine	MO- 6Δ14S(R)	BD4 to BE4 -3Δ7	47.3
		BD6 to BE6	
	MO- 6Δ14S(R)	BDΔ to BFΔ 20H	48.4
		BE7 4ΔH	
	MO- 6Δ12S	-CE4 -40H	46.8
MO- 6Δ12S	-DF6 507	46.9	
		50F	
Safety stitch machine	MO- 6Δ16S(R)	-ΔΔΔ 3Δ0	46.2
			500
	MO- 6Δ16S(R)	BE4 4ΔH	48.2
		DDΔ 5ΔH	
	MO- 6Δ16S(R)	FΔΔ -60H	48.4
	MO- 6943R	-ΔΔΔ -ΔΔ7	47.3
MO- 6Δ43S	-ΔΔΔ -ΔΔH	48.4	
MO-6900G, J serie	MO- 6903G	-0N6 -3D1	51.2
	MO- 6904G(J)	-0F6 -700	50.7
	MO- 6905G	-0M6 -7Δ0	51.7
	MO- 6914G(J)	-CH6 -700	49.3
	MO- 6916G(J)	-FΔ6 -700	48.8

Adjustment Procedures	Results of Improper Adjustment
<p>1) Loosen the setscrew of upper looper ball arm ③ and setscrew ⑤ of the upper looper holder.</p> <p>2) Adjust the clearances between upper looper bracket ④ and upper looper holder ① to approximately 0.2 mm respectively, and tighten setscrew ⑤ of the upper looper holder. (Make sure that the upper looper holder smoothly moves together with upper looper shaft ⑥.)</p> <p>3) Then determine dimension ⑦ from the bottom surface of the frame to the top surface of upper looper holder pin ② before tightening the setscrew of upper looper ball arm ③.</p> <p>(Caution) Replace upper looper holder ① according to the needle gauge size.</p>	<p>○ Inaccurately positioned upper looper holder will cause excessive projection of the upper looper, resulting in stitch skipping, or other troubles.</p> <p>(Caution) To adjust the upper looper ball arm, take dimension ⑦ as standard. Remember that the projecting amount and the height of the upper looper should eventually be properly adjusted. So, confirm the dimensions related to the upper looper.</p>

Standard Adjustment

(8) Positioning the upper looper

1) Height of the upper looper

The distance between the throat plate surface and the blade point of the looper should be as follows when the upper looper is at the extreme left of its travel.

(Unit : mm)

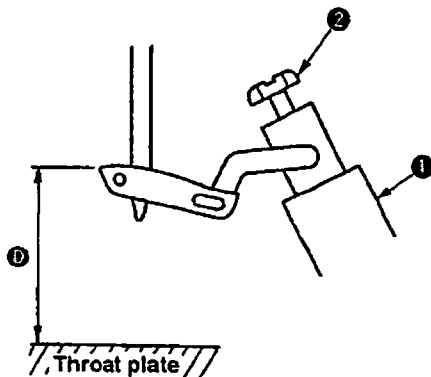

	Model	Dimension ^D
1-needle overlock machine	MO- 6Δ04S(R)-ΔΔΔ ΔΔ0 -ΔΔ6 50M	11.0
	MO- 6Δ04S -ΔΔΔ -ΔΔH	11.3
	MO- 6Λ05S -ΔΔΔ -ΔΔH	11.3
2-needle overlock machine	MO- 6Δ14S(R) BD4 to BE4 BD6 to BE6 -307	10.3
	MO- 6Δ14S(R) BDΔ to BFΔ 20H BE7 4ΔH	11.0
	MO- 6Δ12S -CE4 -40H	11.8
	MO- 6Δ12S -DF6 507 50F	11.0
Safety stitch machine	MO- 6Δ16S(R) -ΔΔΔ -ΔΔ0	11.0
	MO- 6Δ16S(R) DDΔ BE4 FΔΔ 4ΔH 5ΔH	11.3
	MO- 6Δ16S(R) -FΔ6 -60H	12.8
	MO- 6943R -ΛΔΔ -ΔΔ7	10.3
	MO- 6Δ43S -ΔΔΔ -ΔΔH	11.0
MO-6900G,J series	MO- 6903G -0N6 -3D1	13.6
	MO- 6904G(J) -0F6 -700	13.7
	MO- 6905G -0M6 -7Δ0	12.0
	MO- 6914G(J) -CH6 -700	12.9
	MO- 6916G(J) -FΔ6 -700	13.7

2) Longitudinal position of the upper looper

- ① The clearance between the upper and lower loopers should be 0.1 to 0.2 mm when they cross with each other.
- ② The clearance between the upper looper ③ and the needle should be 0 to 0.2 mm.

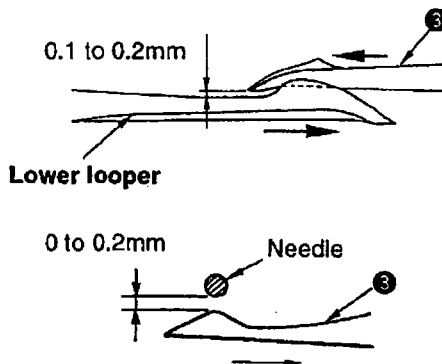
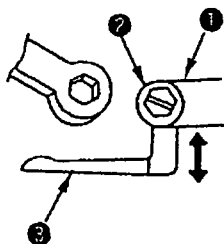

Adjustment Procedures	Results of Improper Adjustment
<p>1) Height of the upper looper</p> <p>① Set a hexagon screwdriver onto setscrew ② at the end of upper looper bracket ① to adjust height ③.</p> <p>② When adjusting the height, pay attention also to the clearance produced between the upper looper and the lower looper at the time of their crossing.</p>	<ul style="list-style-type: none"> ○ If the upper looper has been positioned too high, an excessive clearance will be produced between the upper looper and the needle. As the result, the upper looper thread will fail to catch the needle thread, and stitch skipping occurs. ○ On the contrary, if the upper looper has been positioned too low, the needle point will hit the looper, causing needle breakage. Also the looper will touch other component when the presser foot goes up.
<p>2) Longitudinal position of the upper looper</p> <p>① Loosen setscrew ② at the top end of upper looper bracket ① to move upper looper ③ back or forth for positioning the clearance of 0.1 to 0.2 mm between the upper looper and the lower looper at the time of their crossing or the clearance of 0 to 0.2 mm between upper looper ③ and the needle.</p>	<ul style="list-style-type: none"> ○ Excessive clearance will cause stitch skipping. ○ Insufficient clearance will cause the upper looper to come in contact with the lower looper.

Standard Adjustment

(9) Adjusting the double chain looper (Applicable only to MO-6 Δ 16S/6916R, G, J series)

1) Returning amount of the double chain looper

The distance between the needle center and the blade point of the double chain looper should be 1.5 to 2 mm when the looper is at the extreme left of its travel.

MO-6916G, J series

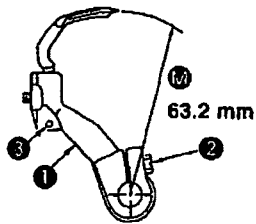

MO-6 Δ 16S, R series

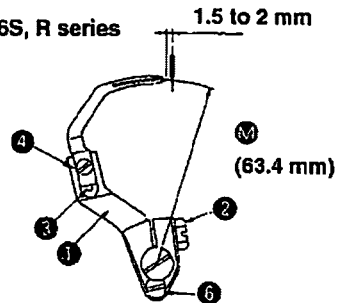

2) Longitudinal motion (Avoid motion)

The standard minor axis of the elliptical motion should be :

3.0 mm (MO-6 Δ 16S, R).

3.5 mm (MO-6916G, J).

Note : The avoid motion should be adjusted in accordance with Needle No.

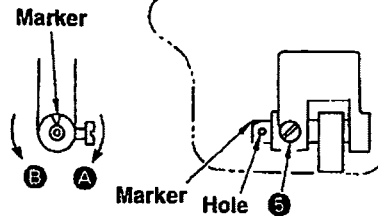

3) Clearance between the double chain looper and the needle

The clearance should be 0.05 to 0.1 mm.

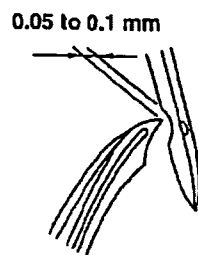

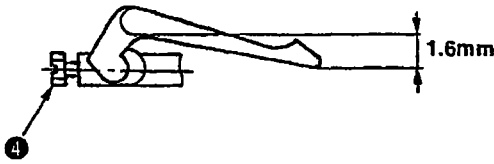
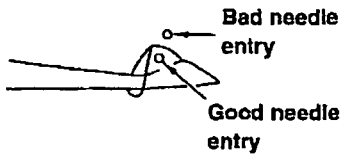
Adjustment Procedures	Results of Improper Adjustment
<p>1) Returning amount of the double chain looper</p> <p>① Loosen setscrew ② of double chain looper driving arm ① to make this adjustment.</p> <p>② Radius ③ of the double chain looper driving arm ① will be 63.4 mm when it is lowered until it comes in contact with stopper pin ④.</p> <p>③ For MO-6916G,J type machines, radius ③ will be 63.2 mm.</p> <p>④ Adjust the tilt of double chain looper with setscrew ④. Adjust the tilt to 1.6 mm.</p> 	<ul style="list-style-type: none"> ○ Excessive return of the double chain looper will cause frequent stitch skipping when filament thread is used. ○ Insufficient return of the double chain looper will cause frequent thread stitch skipping when a spun thread is used.
<p>2) Longitudinal motion (Avoid motion)</p> <p>① Open the cover of the adjusting hole on the rear of the frame, loosen setscrew ⑤, and put a $\varnothing 2$ rod in the hole. Now, make the adjustment by turning the rod back and forth.</p> <p>Marker : This side Minimum (for standard to thin needle) ⑥</p> <p>Marker : Far side Maximum (for thick needles) ⑦</p> <p style="text-align: right;">} As observed from this side</p> 	<ul style="list-style-type: none"> ○ If the avoid motion is too large, triangle stitch skipping will often occur. ○ Insufficient avoid motion will cause the needle point to hit the looper, producing scratches on the needle point or looper.
<p>3) Clearance between the double chain looper and the needle</p> <p>① Temporarily tighten setscrew ② in the double chain looper, and finely adjust the longitudinal position of the double chain looper. Adjust the clearance to 0.05 to 0.1 mm.</p> <p>MO-6916S,R series only</p> <p>② Turn fine adjustment screw ⑥ clockwise to move the double chain looper away from the needle. Turn it counterclockwise to move the double chain looper closer to it.</p>	<ul style="list-style-type: none"> ○ Excessive clearance will cause frequent needle thread stitch skipping. ○ Insufficient clearance will cause to looper to hit the needle, leading to needle breakage or scratches on the looper blade point with consequent thread breakage.

Standard Adjustment

(10) Adjusting the height and clearance of the needle guard

1) For 1-needle or 2-needle overlock machine

Make needle guard **A** lightly come in contact with the top end of needle (bend needle by 0 to 0.05 mm) when the blade point of the lower looper reaches the needle center.

The clearance between needle guard **B** and the needle is 0.1 mm when the needle is at the lowest point of its stroke.

The height of needle guard **B** is 1 mm from the throat plate bottom surface.

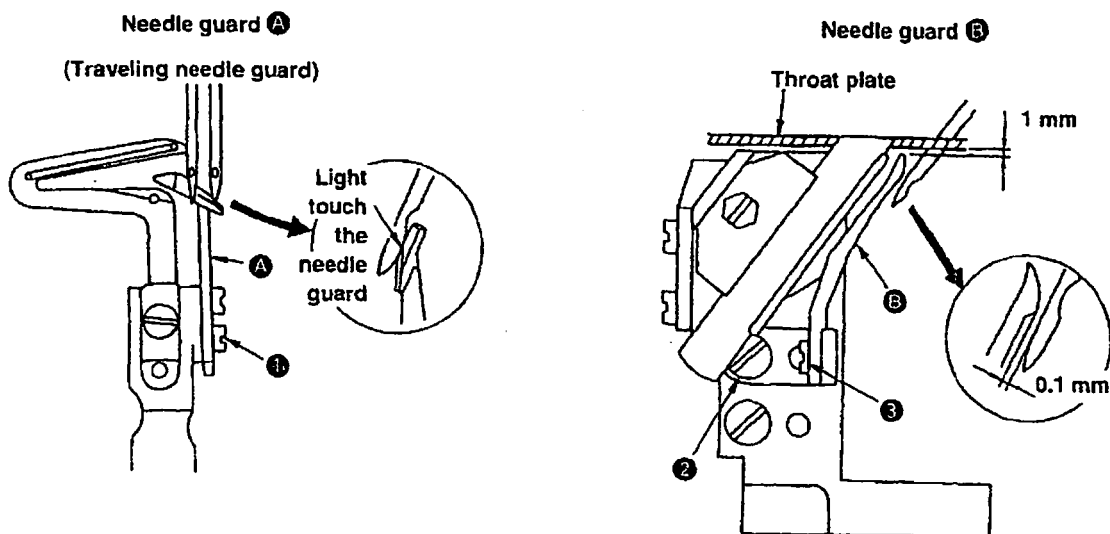

2) For safely stitch machine

The safely stitch machine has four needle guards, **A**, **B**, **C** and **D**. The needle guards **A** and **B** are positioned in the same manner as those for the overlock machine.

The needle guard **C** should be positioned 5 mm below the throat plate bottom surface.

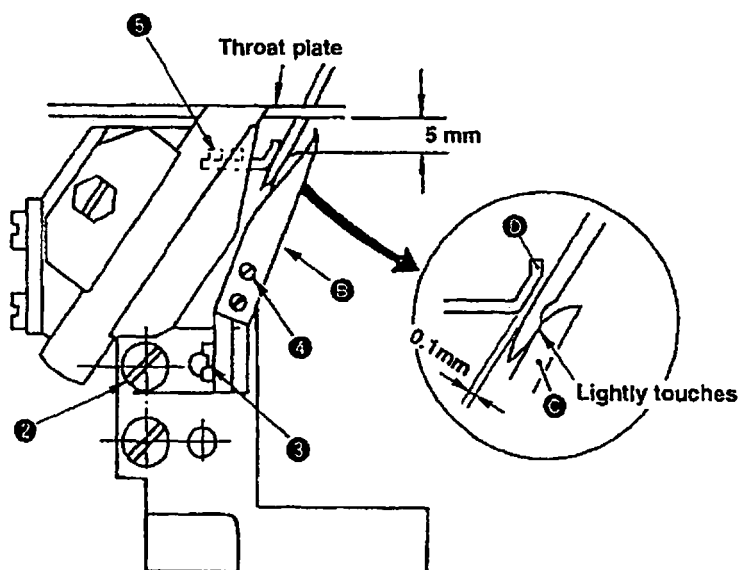

Adjustment Procedures	Results of Improper Adjustment
<p>1) For 1-needle or 2-needle overlock machine</p> <p>① Adjust needle guard A with setscrews 1 in the needle guard so that it lightly comes in contact with the needle (bend needle by 0 to 0.05 mm) when the blade point of the lower looper reaches the needle center.</p> <p>② To adjust the clearance provided between needle guard B and the needle when the needle bar is at the lowest point of its stroke, loosen setscrews 2 in the needle guard support and turn needle guard B to adjust the clearance to 0.1 mm.</p> <p>③ Adjust the height of needle guard B to 1 mm from the throat plate bottom surface with setscrew 3 in the needle guard.</p>	<ul style="list-style-type: none"> ○ Excessively close contact between the needle guard A and the needles will lead to needle bend or stitch skipping. ○ A clearance left between the needle guard A and the needles will cause the looper blade point to come in contact with the needles, leading to needle or blade point breakage, or other troubles. ○ If the needle guard B is too high, thread loops will be damaged with resultant stitch skipping. Also, double chain loops will be affected, causing double chain stitch skipping. ○ If the needle guard B is too low, the needle cooling felt will be lowered, resulting in deteriorated effect of the cooling and needle guard. ○ Excessive clearance between the needle guard B and the needle will cause stitch skipping due to needle shake. On the contrary, insufficient clearance will cause the needle guards to catch the needles between them, leading to wear on the needle guards and scratches on the needles.
<p>2) For safety stitch machine</p> <p>① Loosen setscrews 4 in the needle guard, and adjust the clearance provided between needle guard C and the needle so that it lightly comes in contact with the needle (bend needle by 0 to 0.05 mm).</p> <p>② Adjust the installing height of needle guard C to 5 mm with setscrew 5 in the needle guard.</p> <p>③ Adjust the clearance provided between needle guard D and the needle to 0.1 mm with setscrews 6.</p> <p>(Caution) Check again the clearance provided between needle guard B and the needle after adjusting the height of needle guard C.</p>	<ul style="list-style-type: none"> ○ If the needle guard C is too high, the needle thread loops will be damaged, and stitch skipping occur. If it is too low, the needle points will be crushed. ○ If the clearance between the needle guard C and the needles is too large, the double chain looper blade point will come in contact with the needles, causing the breakage of the needles, causing the breakage of the needles or looper blade point. No clearance left between them will cause them to come in excessively close contact with each other, and wear on the needle guard and scratches on the needles will occur. ○ Excessive clearance left between the needle guard D and the needles will cause stitch skipping due to needle shake, and insufficient clearance will cause the needle guards to catch the needles between them, leading to wear on the needle guards and scratches on the needles.

Standard Adjustment

(11) Adjusting the height of the feed dog

The height of main feed dog ② from the top surface of the throat plate ① should be as follows when it is at its highest position.

(Unit : mm)

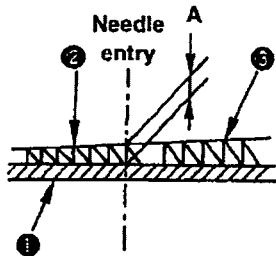

Model	Dimension A
MO-6 Δ 00S Series	1.0
MO-6904G Series	1.3
MO-6914G Series	1.2
MO-6916G Series	1.1

Auxiliary feed dog ④ is 0.5 mm lower than main feed dog ②.

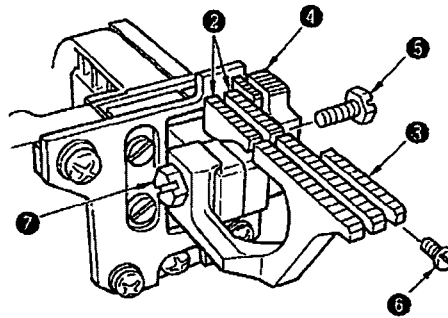
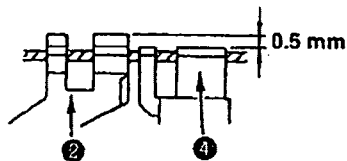

(12) Adjusting the tilt of the feed dog

Tilt of the feed dogs when the feed dogs have come up most.

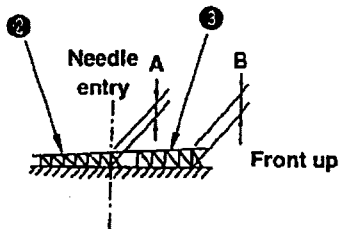

When the feed dog juts out the top surface of the throat plate

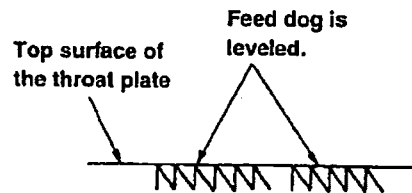

(Unit : mm)

Model	Dimension A	Dimension B
MO-6 Δ 00S Series	1.0	(1.2)
MO-6904G Series	1.3	(1.5)
MO-6914G Series	1.2	(1.4)
MO-6916G Series	1.1	(1.3)

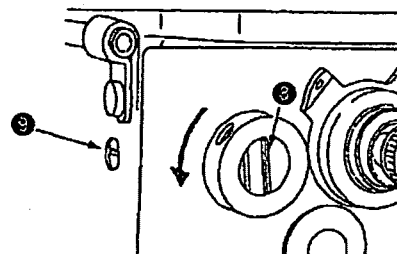

Adjustment Procedures	Results of Improper Adjustment
<p>1) Adjust the height of main feed dog ② to dimension A with setscrew ⑤.</p> <p>2) Adjust the height of differential feed dog ③ with setscrew ⑦ so that there is no difference in level between main feed dog ② and differential feed dog ③.</p> <p>3) Adjust the height of auxiliary feed dog ④ with setscrew ⑥ so that it is 0.5 mm lower than main feed dog ②.</p>	<ul style="list-style-type: none"> ○ If the feed dogs are too high, the needles will be deflected and broken when sewing heavy-weight materials. The feed dogs will tend to suffer scratches when sewing light-weight materials. Puckering will frequently occur. ○ If the feed dogs are too low, insufficient feed power will result. ○ If the auxiliary feed dog is too high, chain-off thread will be often jammed. ○ If the main feed dog and differential feed dog are set at different heights, proper differential feeding action will be hindered.
<p>1) Use the tilt of the feed dog when it is in its highest position as a reference and adjust so that the feed dog is flush with the throat plate when the feed dog juts out the throat plate.</p> <p>2) Feed bar shaft ⑧ consists of an eccentric shaft. Loosen setscrew ⑨ to perform adjustment.</p> <p>When the marker line is set at middleThe feed dog will be flat.</p> <p>When the marker line is set at bottomThe feed dog will be tilted with its front up (in the arrowed direction).</p> <p>When the marker line is set at topThe feed dog will be tilted with its front down.</p> <p>(Caution) The marker line should be used just as the reference since it slightly differs with that of each machine due to the disparity of the components. Confirm the accurate tilt of the feed dog by observing the feed dog itself.</p>	<ul style="list-style-type: none"> ○ When tilted with the front up Good material catching will be obtained. ○ When tilted with the front down Uneven feed and puckering will be effectively prevented.

Standard Adjustment

(13) Adjusting the differential feed ratio

MO-6000S, R Serie

<p>(Standard) Gathering: 1: 2 Stretching: 1: 0.7</p>	<p>(Max, stretching) Gathering: 1:1.6 Stretching: 1:0.6</p>	<p>(Max, gathering) Gathering: 1: 4 Stretching: 1: 1.3</p>

MO-6900G, J Serie

<p>(MO6904G (J), MO6916G (J)) Gathering: 1: 1.75 Stretching: 1: 0.6</p>	<p>(MO-6914G (J)) Gathering: 1:2.0 Stretching: 1:0.7</p>	

(14) Longitudinal position of the feed dog

When the feed pitch is maximized and the differential feed ratio is also maximized, the clearances of the front and rear ends of the feed dog, and the throat plate should be spaced approximately 0.5 mm respectively.

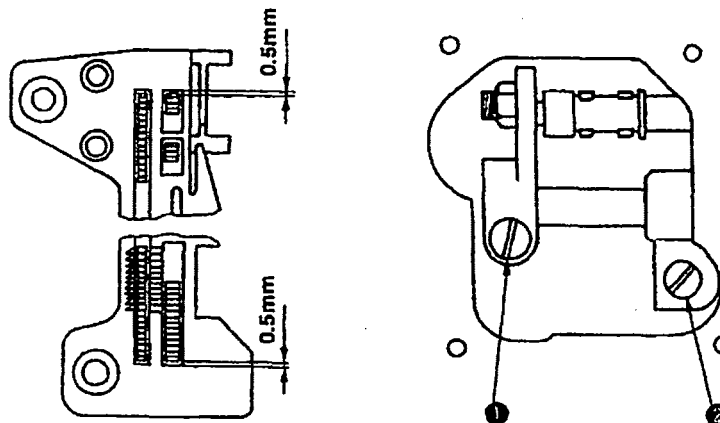

Adjustment Procedures	Results of Improper Adjustment
<ol style="list-style-type: none"> 1) Remove cover ❶ on the rear of the frame and loosen main feed pin and nut ❸. 2) Move main feed pin ❷ up or down to adjust the differential feed ratio. 3) Adjust so that the lower engraved marker line on main feed rocker ❹ aligns with the center of nut ❸. (Standard) 4) When adjusting the maximum stretching, adjust main feed pin ❷ to the highest position. 5) When adjusting the maximum gathering, adjust main feed pin ❷ to the lowest position. 6) After performing adjustment, tighten the main feed pin and nut ❸, and install cover ❶. 	
<ol style="list-style-type: none"> 1) Remove the cover on the rear of the frame, loosen main feed bracket clamping screw ❶ and differential feed bracket clamping screw ❷, and adjust the clearances provided between the front and rear ends of the feed dogs and the slots in the throat plates to approximately 0.5 mm. Then tighten main feed bracket clamping screw ❶ and differential feed bracket clamping screw ❷. 	<ul style="list-style-type: none"> ○ If the clearance provided between the throat plate and the feed dog is too small, they will come in contact with each other when the sewing machine runs at high speed.

Standard Adjustment

(15) Adjusting the presser foot

1) Adjusting the tilt of the presser foot

The presser foot should be positioned so that the feed dogs go down under the specified presser foot pressure, and the presser foot sole comes in contact evenly with the throat plate surface.

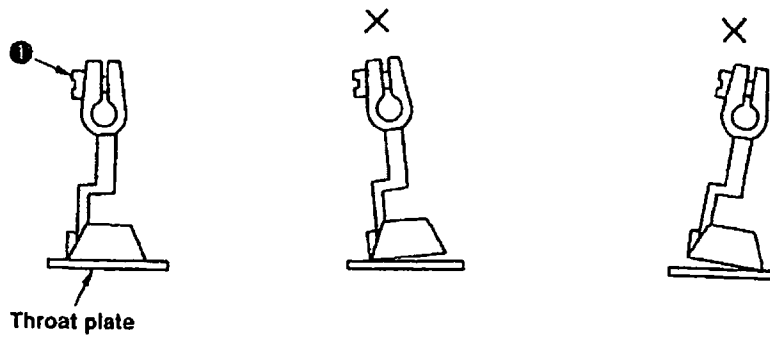

2) Adjusting the micro-lifting mechanism of the presser foot

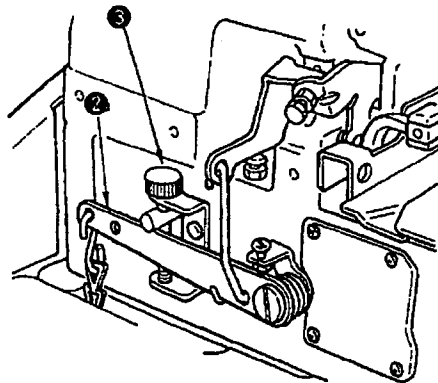

Adjustment Procedures	Results of Improper Adjustment
<p>1) Adjusting the tilt of the presser foot</p> <p>① Turn the handwheel and place the feed dog in the position where the feed dog does not jut out the top surface of the throat plate.</p> <p>② Loosen setscrew ❶ and adjust so that the presser foot sole comes in contact evenly with the throat plate top surface. Then tighten setscrew ❶.</p> <p>(Reference) Accurate adjustment can be made by using two pieces of thin paper to check for even drawing-out tension. In addition, even contact of the presser foot with the throat plate top surface is achieved rather easily by tightening the screw while pushing the right side of the presser foot.</p>	<p>○ Uneven contact will result in bad straight material feed, weak feed power, or puckering.</p>
<p>2) Adjusting the micro-lifting mechanism of the presser foot</p> <p>① When moving presser lifting lever ❷ just a little, perform it with fine adjustment screw ❸.</p>	

Standard Adjustment

(16) Positioning the upper knife arm shaft

The upper knife shaft should be positioned 34 mm above the top surface of the throat plate when it is at its highest position.

MO-6△16S(R)-F△6-60H : 35 mm

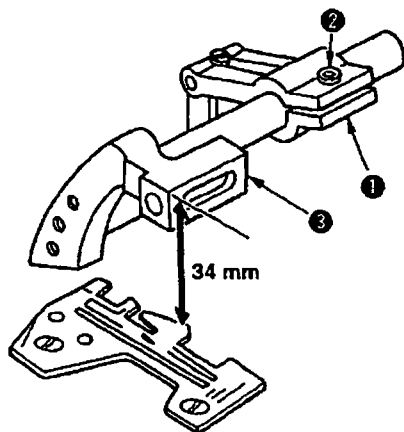

(17) Positioning the upper and lower knives, and available overedge widths

1) Lower knife

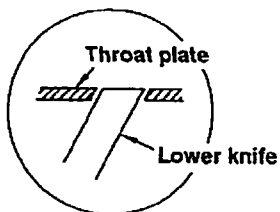

2) Upper knife

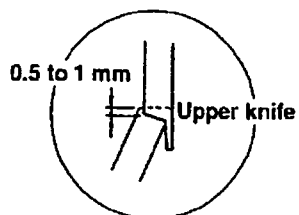

3) Overedging width

Overedging width can be adjusted from 1.6 to 6.4 mm.

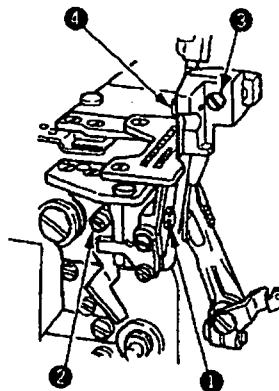

Adjustment Procedures	Results of Improper Adjustment
<p>1) Remove the upper cover, loosen setscrew ② in upper knife driving arm ①, and turn upper knife shaft ③ to adjust the position from the top surface of the throat plate to 34 mm.</p> <p>(Caution) Be sure to fully tighten the setscrew since upper knife shaft ③ is subjected to high load.</p>	<ul style="list-style-type: none"> ○ Improperly positioned upper knife arm shaft will come in contact with the frame. If it is moved with the position of the upper knife unchanged, proper engagement of the knives will be disturbed, prohibiting sharp cutting of the knives.
<p>1) Lower knife</p> <p>① Adjust the vertical position of the lower knife by screw ① so that the blade top aligns with the top surface of the throat plate.</p> <p>② Tighten screw ② after bringing the upper knife to its lowest position of its stroke.</p> <p>2) Upper knife</p> <p>① Adjust the position of the upper knife by screw ① so that the engagement with the lower knife is 0.5 to 1 mm when the upper knife is in the lowest position of its stroke.</p> <p>(Caution) Adjust the lateral position of the lower knife by screw ③. Adjust the lateral position of the upper knife by screw ⑤. After performing adjustment, be sure to fix the knife. Otherwise, the durability of the knife will be affected.</p> <p>3) Overedging width</p> <p>① Adjust the overedging width in the following way : Laterally position the upper knife before loosening screw ②. Tighten screw ② when the upper knife has settled by itself under the pressure applied by the spring. Repeat this adjustment procedure to obtain desired overedging width.</p>	<ul style="list-style-type: none"> ○ The lower knife, if positioned too high, will catch materials or cause no contact of the presser foot with the throat plate top surface. ○ If the lower knife is positioned too low, the cutting width will be changed or materials will be caught by the lower knife. ○ The upper knife, if positioned too high, will fail to cut materials. ○ Unsharp cutting or abnormal wear on the knives will result unless the lower knife is laterally positioned and fixed at a position where it has settled by itself under the upper knife spring.

Standard Adjustment

(18) Resharpener of the knife

Lower knife gauge
Part No. 11996907

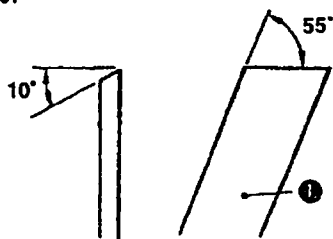

(19) Position of the thread cam (Applicable only to MO-6△16△ series)

1) Adjustment of the thread cam

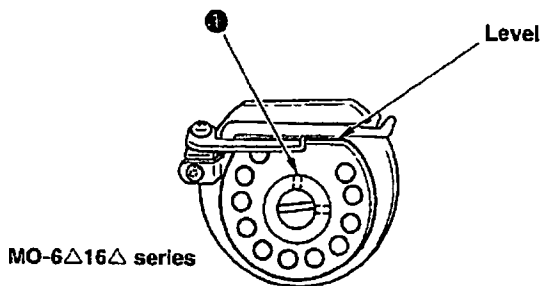

2) Adjusting looper thread cam thread guides A and B and the looper thread cam nail

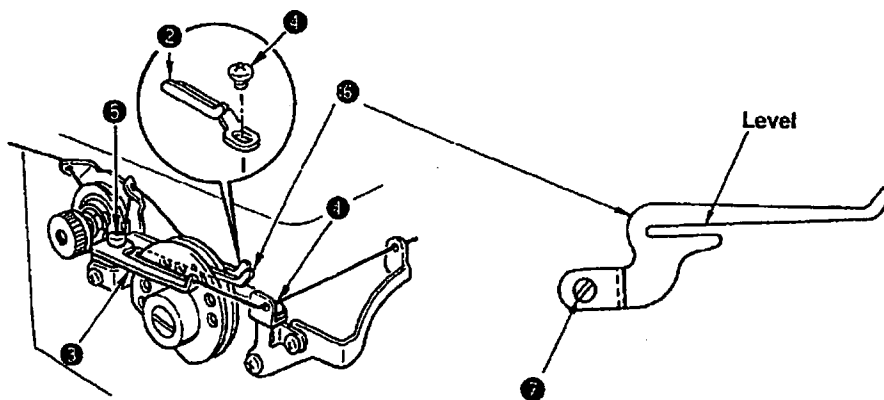

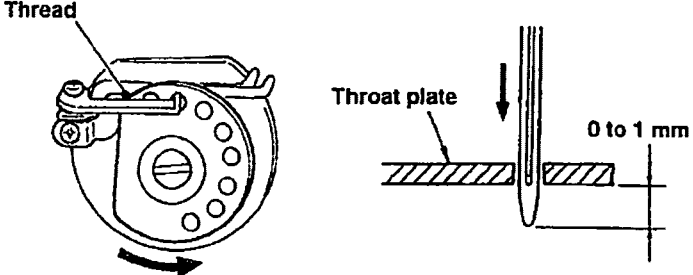
Adjustment Procedures	Results of Improper Adjustment
<p>1) When the knives have become dull, fully sharpen lower knife ❶ until the contact mark of it disappears.</p> <p>2) When the upper knife has become dull, replace it with a new one. (This is because the upper knife is a serrated carbide knife.)</p>	<ul style="list-style-type: none"> ○ If the 10° angle of the lower knife is exceeded, the durability of the knife will be deteriorated, often resulting in blade chipping. ○ If the angle is smaller than 10°, the knife will be dull. ○ If the 55° angle is not observed, the knife may catch materials.
<p>1) Adjusting the thread cam</p> <p>❶ Adjust the position of the thread cam by its setscrew ❶ with the needles at their upper dead point so that the straight section of the thread cam is leveled.</p> <p>❷ Laterally position the thread cam so that the looper thread cam nail is located at the center of the thread cam groove.</p> <p>[How to check for proper positioning] Check that the thread cam releases the looper thread when the needle tip begins to come out of the bottom surface of the throat plate by 0 to 1 mm.</p>  <p>2) Adjusting the looper thread cam thread guides A and B and the looper thread cam nail</p> <p>❶ Install looper thread cam thread guides A ❷ and B ❸ at the center of the slots with setscrews A ❹ and B ❺.</p> <p>❷ Install looper thread cam nail ❻ with setscrew ❼ so that the straight section of the forked portion is leveled.</p>	<ul style="list-style-type: none"> ○ If the timing of the thread cam is too early, the needle point will fail to enter a thread triangle, resulting in looper thread stitch skipping. ○ If the timing of the thread cam is too late, puckering and loose looper thread stitches will result. <ul style="list-style-type: none"> ○ If the chain looper thread guide is moved away from you, the take-up amount of the lower looper thread will decrease. In this case, puckering may result there by impairing the feeling of the finished product.

Standard Adjustment

(20) Adjusting the throat plate support

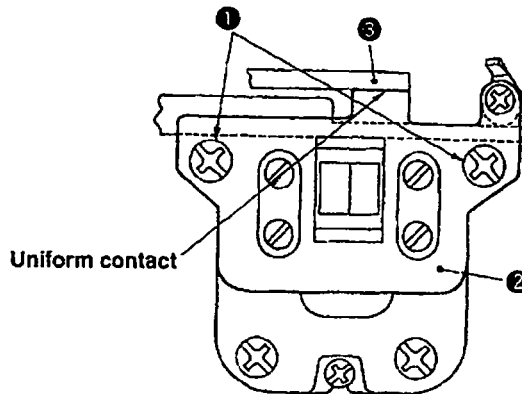

(21) Adjusting the feed mechanism cover presser

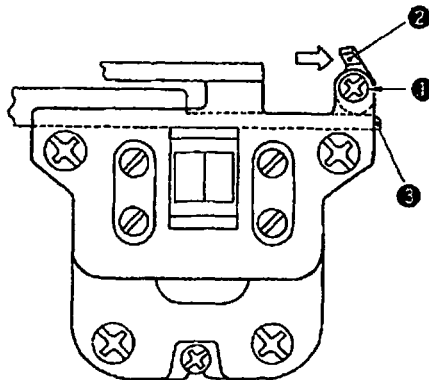

(22) Adjusting the looper cover

- The looper cover should smoothly close without coming in contact with upper knife ① when slowly closing looper cover ② with upper knife ① in its lowest position of its stroke.

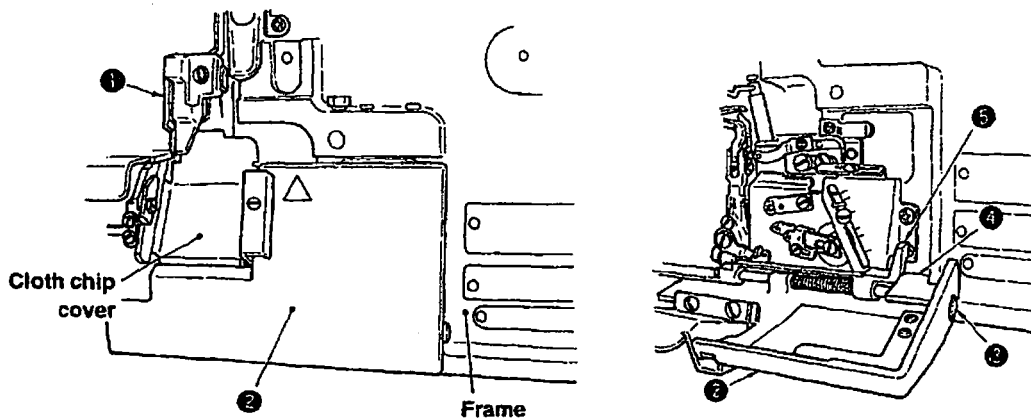

Adjustment Procedures	Results of Improper Adjustment
<p>1) Loosen setscrews ❶ and adjust so that throat plate support ❷ should not come in single-sided contact but come in uniform contact with throat plate ❸ using setscrews ❶.</p>	<p>○ If the throat plate support comes in single sided contact with the throat plate or does not come in contact with it, the throat plate will vibrate severely.</p>
<p>1) Loosen setscrew ❶ and press feed mechanism cover presser ❷ in the direction of arrow.</p> <p>2) Press feed mechanism cover ❸ and tighten setscrew ❶ so that the feed mechanism cover should not rise.</p> <p>(Caution) Check that feed mechanism cover ❸ is pressed so that it should not rise.</p>	<p>○ If the feed mechanism cover is not fully pressed and the cover rises, oil leakage will be caused.</p>
<p>1) Close looper cover ❷, loosen setscrew ❸, and move looper cover guide plate ❹ back and forth until the looper cover is brought to a position where the cover smoothly closes.</p> <p>2) Move looper cover guide plate ❹ until it slightly comes in contact with looper cover receiving bracket ❺. Now, fix the guide plate by tightening setscrew ❸.</p>	

Standard Adjustment

(23) Adjusting the cloth chip cover

- When cloth chip cover ③ is pressed away from you, it should not rattle.
In addition, the cloth chip cover should not come in contact with upper knife ① and lower looper ④.

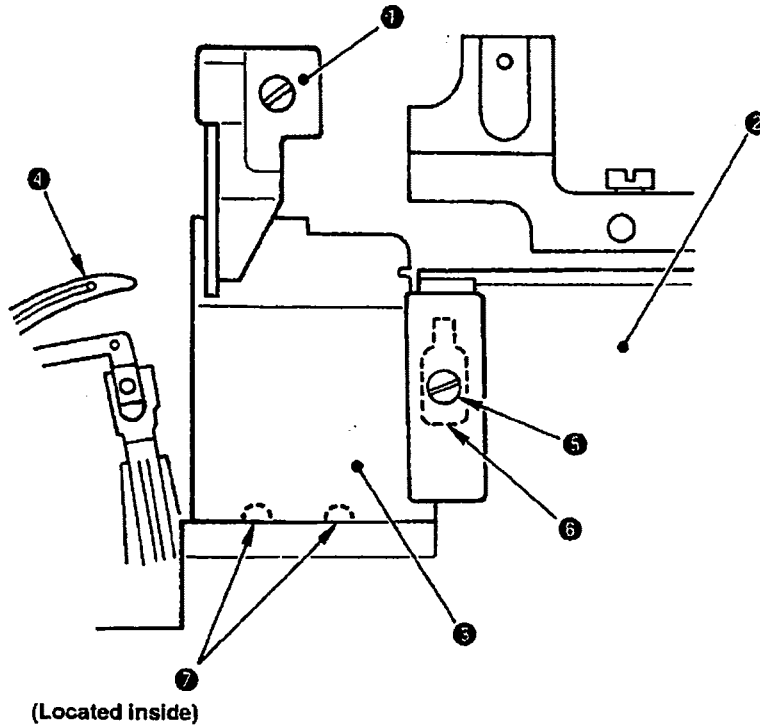

Adjustment Procedures	Results of Improper Adjustment
<ol style="list-style-type: none"> 1) Loosen setscrew ⑤ and temporarily tighten the setscrew with cloth chip cover stopper ⑥ raised. 2) Loosen setscrews ⑦ in the cloth chip cover, and adjust the longitudinal position of cloth chip cover ③. 3) Loosen setscrew ⑤ in the cloth chip cover stopper again, and press cloth chip cover stopper ⑥ downward until the stopper slightly comes in contact with looper cover ②. Now, tighten setscrew ⑤. 4) Finally, confirm that cloth chip cover ③ comes in contact with neither upper knife ① nor lower looper ④. 	

Standard Adjustment

(24) Adjusting the needle mechanism

1. Disassembling

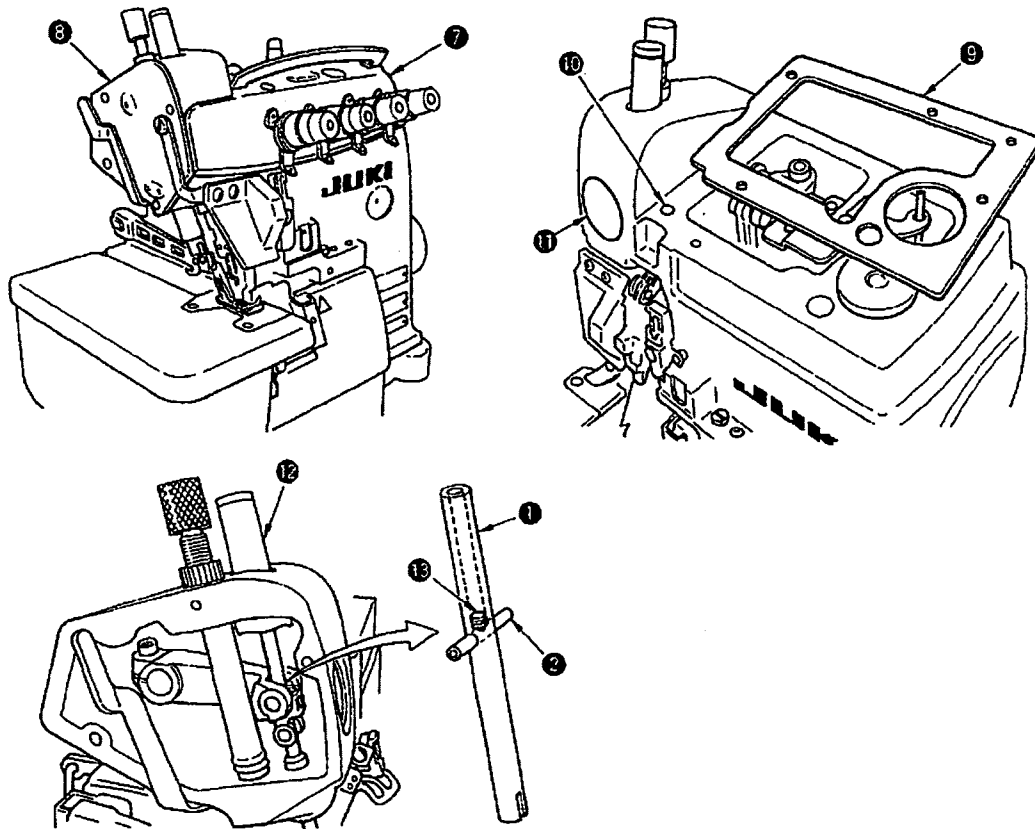

2. Adjustment

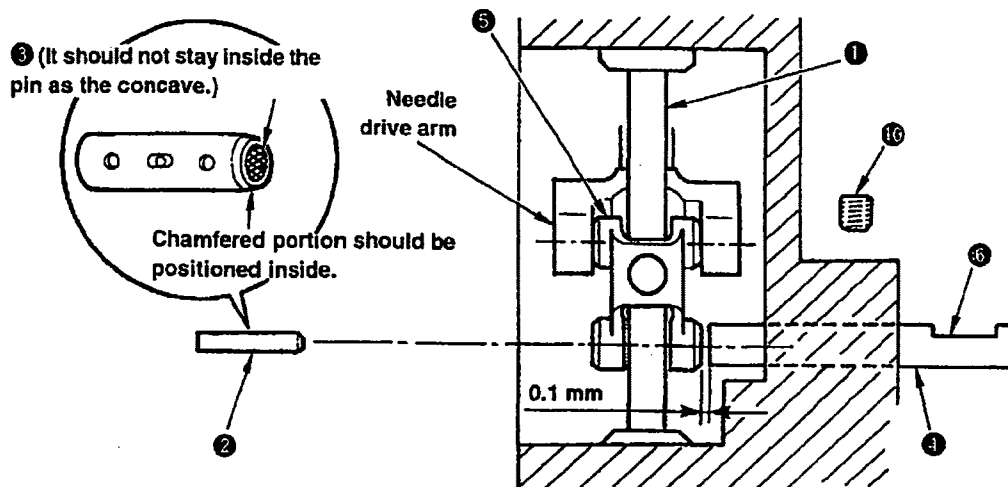

Standard Adjustment

(25) Position of the upper looper lubricating pin

1) Orientation of the lubricating pin

Oil inlet ② of upper looper lubricating pin ① should face upward.

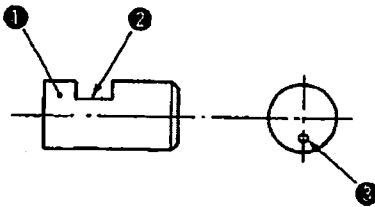

2) Setting the lubricating pin

The clearance provided between upper looper lubricating pin ① and upper looper bracket ④ should be 0.15 mm.

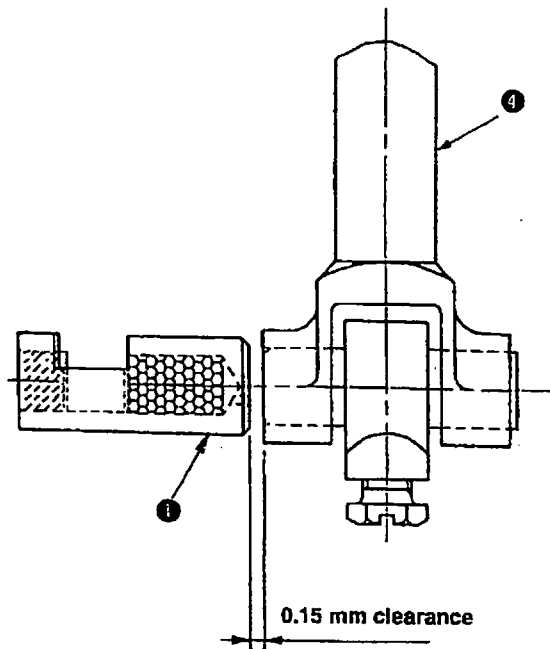

Adjustment Procedures	Results of Improper Adjustment
<p>1) Orientation of the lubricating pin</p> <p>① When upper looper lubricating pin ❶ is set with oil inlet ❷ faced upward, lubricating hole ❸ is in the lower section as observed from this side.</p> <p>2) Setting the lubricating pin</p> <p>① Remove the oil reservoir, loosen the setscrew and adjust the clearance provided between upper looper lubricating pin ❶ and upper looper bracket ❹ to 0.15 mm using a 0.1 5mm clearance gauge or the like.</p>	<p>○ If the oil inlet does not face upward, oil will not be fed resulting in seizure.</p> <p>○ If the clearance provided between the upper looper lubricating pin and the upper looper bracket is too small, the related components will come in contact with each other.</p> <p>○ If the clearance provided between the upper looper lubricating pin and the upper looper bracket is too large, oil will not be fed resulting in seizure.</p>

Standard Adjustment

(26) Longitudinal momentum of the top feed dog (Top feed amount)

Longitudinal momentum (top feed amount) of the top feed dog is possible up to 7.5 mm.

Longitudinal momentum (top feed amount)

	Max.	Min.
Standard	7.5mm	1mm
MO-6916R-F△6-△△H	7mm	2.5mm
MO-6900J	7mm	2.7mm

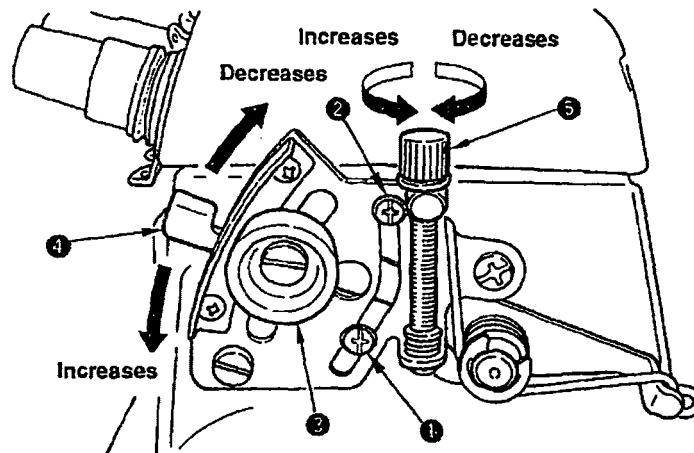

(Caution) Motion of the top feed is not interlocked with the motion of the bottom feed. The longitudinal momentum (top feed amount) of the top feed is determined only by the position of top feed lever ④.

Adjustment Procedures	Results of Improper Adjustment
<p>1) Changing the longitudinal momentum (top feed amount) of the top feed dog</p> <p>① Loosen top feed lock nut ③ and move top feed lever ④ in the direction of the arrow mark to adjust the stroke.</p> <p>② When top feed fine adjustment screw ⑤ is used, it is possible to slightly move top feed lever ④.</p> <p>2) Changing the maximum momentum</p> <p>① Loosen setscrew ① in the differential feed adjustment stopper and lower the stopper to increase the maximum momentum and raise the stopper to decrease it.</p> <p>② After the adjustment, securely tighten setscrew ① in the differential adjustment stopper.</p> <p>3) Changing the minimum momentum</p> <p>① Loosen setscrew ② in the differential feed adjustment stopper and lower the stopper to increase the minimum momentum and raise the stopper to decrease it.</p> <p>② After the adjustment, securely tighten setscrew ② in the differential adjustment stopper.</p>	<p>○ If the min. stroke is decreased to 1 mm or less, the components mounted inside the machine head may come in contact with among one another. It is therefore necessary to set the min. stroke to 1 mm or more.</p> <p>○ If the min. stroke is decreased to 2.5 mm or less for safety stitch machines of 50H or 60H type, the top feed dog may come in contact with the upper looper holder. It is therefore necessary to set the min. stroke to 2.5 mm or more for the aforementioned types of machines.</p>

Standard Adjustment

(27) Vertical momentum of the top feed dog

Relation between the position of vertical adjustment pin and the vertical momentum

Adjusting position	Vertical momentum	Application
Striking to end of groove.	3.5mm	Light weight material
Marker line position A	5.0mm	Light- to medium-weight materials
Marker line position B	6.5mm	Medium- to heavy-weight materials
1 to 1.5 mm on this side from striking to end of groove	8.5mm	Extra heavy-weight materials

- * In case of adjusting the position of vertical adjustment screw ②, check that the pin does not come in contact with upper knife support, needle clamp, etc. Then securely tighten vertical adjustment screw ②.

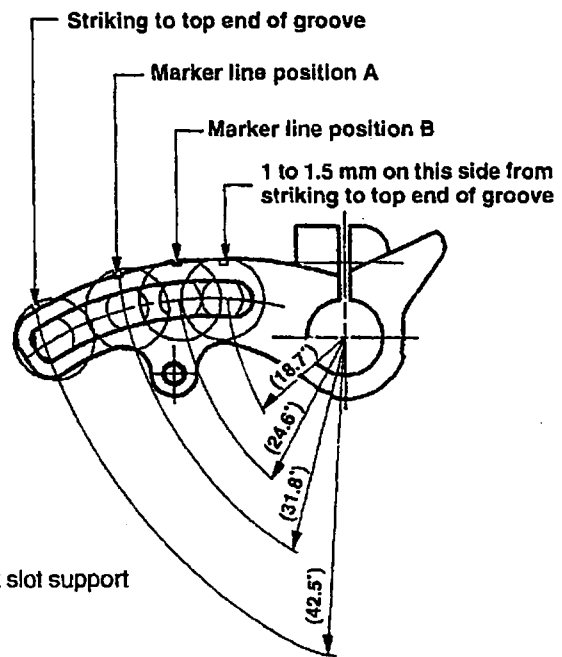
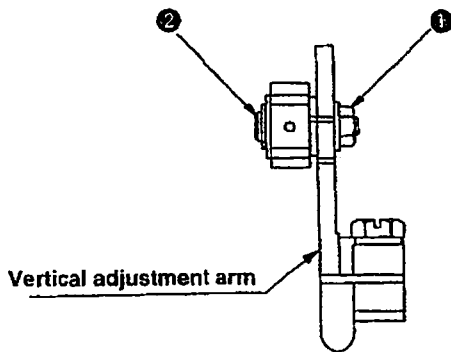

Assembling position of locus cut base and exhaust slot support

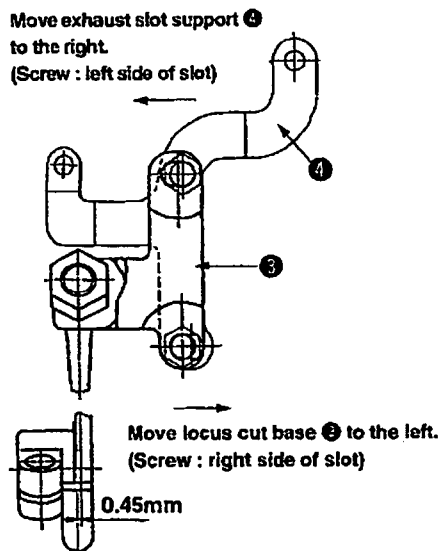

Check that the locus cut screw is adjusted to the position (almost the center) of the aforementioned dimension of the vertical adjustment arm support section.

Adjustment Procedures	Results of Improper Adjustment
<ol style="list-style-type: none"> 1) Remove the top cover, locus cut base ❸ and exhaust slot support ❹. 2) Loosen vertical adjustment nut ❶ and move vertical adjustment pin ❷ to a proper position. 3) After the adjustment, stop locus cut base ❸ and exhaust slot support ❹ at the position as shown in the figure. 	<ul style="list-style-type: none"> ○ When the position of vertical adjustment pin ❷ is changed, the vertical momentum of top feed dog changes. ○ When vertical adjustment pin ❷ is moved toward the top end of vertical adjustment arm, the momentum is decreased and when it is moved to the root, momentum is increased. ○ When the vertical momentum is increased, jumping occurs and noise may occur at high speed. In this case, tighten the upper

Standard Adjustment

(28) Adjusting the height of the top feed dog

Adjusting the position of lowest point of the top feed dog

It is standard that the top feed dog is 1.0 mm (safety stitch machine : 0.8 mm) from the top surface of the throat plate when the top feed dog is in the lowest point of its stroke.

It is possible to adjust the position to approximately 1.0 mm above or below the standard adjustment.

(Reference) The standard of the height of the bottom feed dog (main and differential feed dogs) is 0.8 mm from the top surface of the throat plate and flush with it when the bottom feed dog is in the highest point of its stroke.

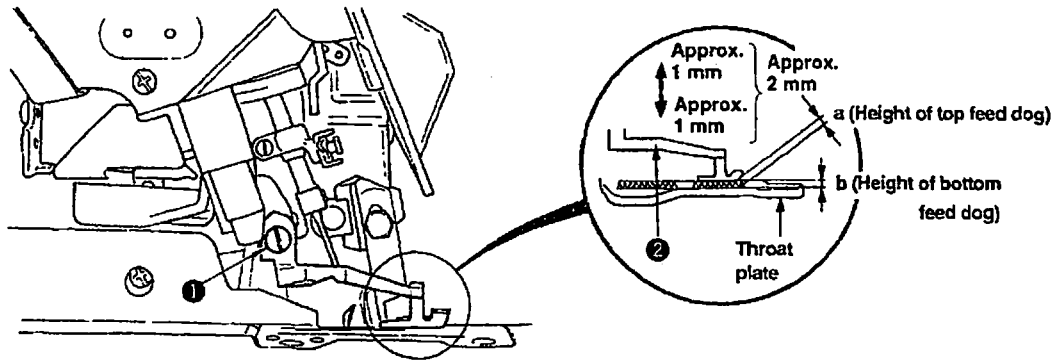

○ Adjusting top/bottom feed dogs of various models of the subclasses

(Unit : mm)

Model name	Top feed dog height a	Bottom feed dog height b
MO-6904R	0△△ -30△	0.8
	500	
	50M	1.0
MO-6914R	△△△ -△0△	0.8
	△4△	
MO-6916R	△△△ -30△	0.8
	△△△ -50H	0.8
	△△△ -60H	1.3
MO-6943R	1△6 -307	0.8
MO-6904J	0F6 -700	1.3
MO-6914J	CH6 -700	1.2
MO-6916J	FH6 -700	1.1

Adjustment Procedures	Results of Improper Adjustment
<p>1) Loosen setscrew ❶ in the top feed dog and move top feed dog ❷ up or down to adjust the height.</p> <p>(Caution) 1. Perform the adjustment in the state that the standard top feed pressure is applied.</p> <p>2. Top feed dog ❷ is removed and personal injuries may occur. Use a rather large-sized screwdriver and securely fix setscrew ❶ in the top feed dog.</p>	<ul style="list-style-type: none"> ○ When top feed dog is installed higher than the standard Sewing of heavy-weight materials is possible. However, a clearance is provided between top and bottom feed dogs, and partial shirring performance of light-weight materials or feed force is decreased. ○ When top feed dog is installed lower than the standard Partial shirring performance or feed force is increased. However, when overlapping amount of top and bottom feed dogs is excessively increased, feed dog defect is apt to occur. Besides, sound may become higher. ○ In case of sewing heavy-weight materials It is possible to sew even when vertical stroke is increased. Refer to "(27) Vertical momentum of the top feed dog".

Standard Adjustment

(29) Locus cut of the top feed dog

Locus cut mechanism makes longer the section where the feed dog actually feeds cloth by leveling the lower side of the locus of top feed dog motion.

By this mechanism, the effect of prevention of irregular stitches can be obtained when sewing materials thicker than medium-weight ones such as knitted fabrics or the like although the effect is less for light-weight materials.

The locus cut mechanism does not work in the state of delivery.

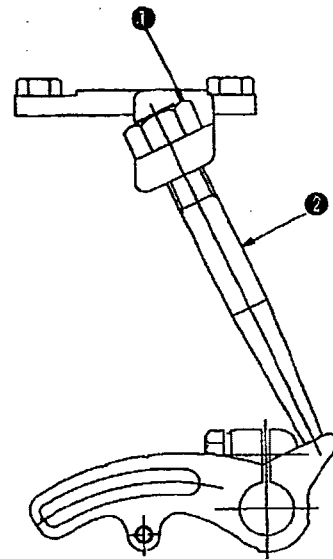
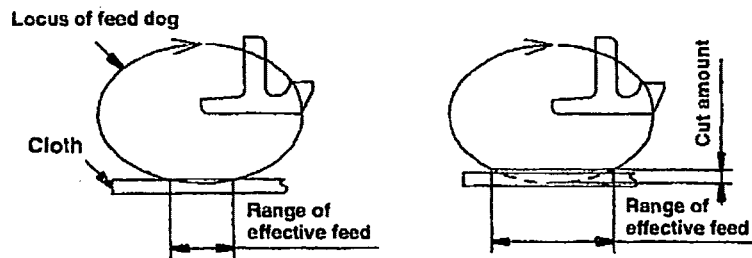

Set the standard of cut amount to approximately 0.5 mm.

(30) Adjusting the longitudinal position of the top feed dog

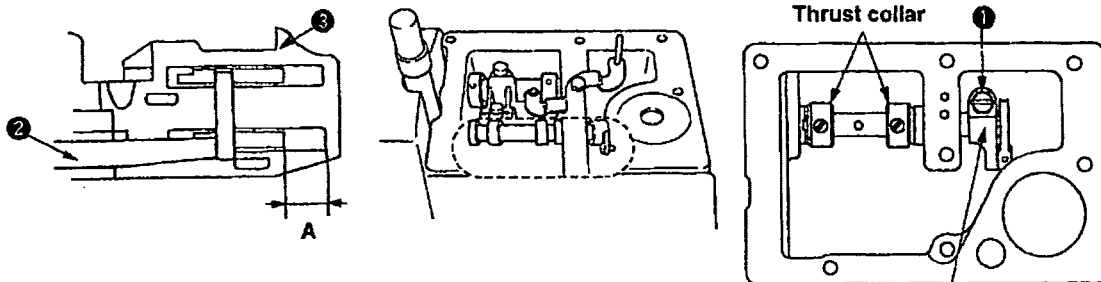

Clearance between top feed dog ② and the groove of presser ③, when top feed stroke is maximum, is as shown in the list below.

Clearance between top feed dog ② and groove of presser ③ when top feed dog ② travels to the front end = dimension A

(Unit : mm)

Model name	dimension A
MO -6916R-F△6 -50H F△6 60H	0.8
MO -6943R -1D6 -307	1.0
All models of MO-6900R, and J excluding aforementioned models	0.5

Adjustment Procedures	Results of Improper Adjustment
<p>1) Remove the top cover.</p> <p>2) Turn the handwheel to bring the top feed dog to the lowest point of its stroke.</p> <p>3) Loosen locus cut screw nut ❶ and tighten locus cut screw ❷. Then the top feed dog rises.</p> <p>4) When a proper cut amount is obtained, tighten locus cut screw nut ❶ so that locus cut screw ❷ does not turn.</p> <p>5) Loosen the setscrew in the top feed dog and lower the top feed dog to the position where it bites cloth.</p> <p>(Caution) 1. When using the machine with locus cut, use the machine at a speed of 5,500 rpm or less.</p> <p>2. When the cut amount exceeds 1 mm or more, a forced load is applied to the mechanism. Use the machine with locus cut of less than 1 mm.</p>	<p>○ The lifted amount from the lowest point in the step 3) is the cut amount. In this state, the clearance between top and bottom teeth is increased as large as the cut portion and feed force is decreased. Be sure to adjust the biting amount of cloth by lowering the top feed dog in the step 5).</p>
<p>1) Remove the top cover and loosen clamping screw ❶ in the top feed arm C to adjust the position.</p> <p>2) The tightening torques of clamping screw ❶ in the top feed arm C after the adjustment is 80N.</p> <p>(Caution) 1. Do not completely loosen clamping screw ❶ in the top feed arm C.</p> <p>2. If clamping screw ❶ in the top feed arm C is loosened and has moved to the right or left, completely loosen it, turn the handwheel and tighten it at the position where it comes naturally.</p>	<p>○ When dimension A is improper, top feed dog ❷ comes in contact with presser ❸, and noise occurs.</p> <p>Besides, the dimension is excessively improper, the top feed dog may come in contact with other components in the frame. Be careful when performing the adjustment.</p>

Standard Adjustment

(31) Adjusting the lateral position of the top feed dog

Clearance between top feed dog ④ and presser ③ is 0.2 mm.

$a = a'$ (0.2 mm)

$b = b'$ (0.2 mm)

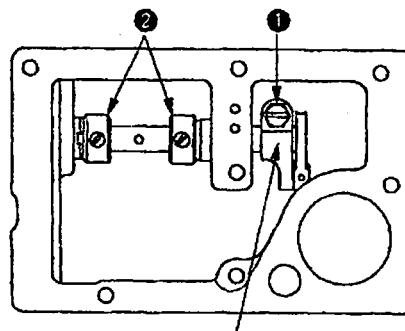
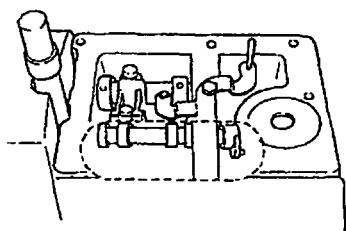
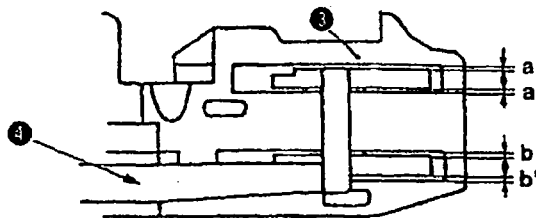

Top feed arm C

- (Caution) 1. Adjust the position only when there is a concrete problem that presser ③ and top feed dog ④ come in contact with each other and noise occurs, the left and right clearances are excessively different from each other and trouble occurs, etc.
2. When the adjustment value is improper, there is the possibility that contact among the components occurs, a bad influence is given to the durability of the sewing machine or the like since the top feed mechanism is strictly assembled because of the space. So, be careful.

Adjustment Procedures	Results of Improper Adjustment
<p>1) Loosen the setscrew in the feed bar guide B. Refer to "(33) Adjusting the feed bar guides A and B".</p> <p>2) Remove the top cover and loosen setscrew ❶ in the top feed arm C. Refer to (30) Adjusting the longitudinal position of the top feed dog.</p> <p>3) Loosen the setscrews in thrust collars ❷ located on the both sides of the horizontal shaft and move the set of horizontal shaft, top feed bar and top feed dog to the predetermined position in the thrust direction (direction you desire to adjust the position). Then fix two thrust collars ❷ at the position.</p> <p>(Reference) When loosening the setscrews in thrust collars ❷, do not simultaneously loosen the two setscrews. First, loosen thrust collar ❷ on the side of moving direction and fix it at the predetermined position. In the state of pressing it in the direction, check that contact at the lateral position or at the top feed mechanism does not occur. After the checking, move and fix the remaining thrust collar ❷. The aforementioned procedure can perform good adjustment.</p> <p>4) Tighten the respective setscrews by reversing the aforementioned order and perform the adjustment.</p>	<p>○ Excessive move in both directions of cloth base side and handwheel side produces the contact of top feed bar with the respective sections of top feed mechanism.</p> <p>(Fully check the change of torque, engagement, or noise at the time of adjustment.)</p>

Standard Adjustment

(32) Position of the motion of the top feed dog

Adjusting the position of the motion of the top feed dog

Loosen the setscrew in horizontal arm A ❶ and move the position of horizontal arm A ❶ to change the position of the motion of the top feed dog.

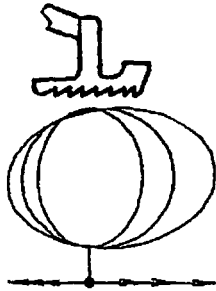

○ Intermediate constant (standard)

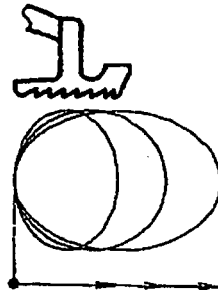

○ Rear constant

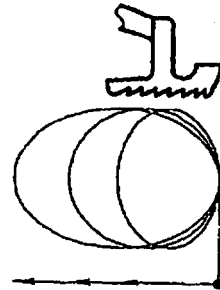

○ Front constant

○ Intermediate constant

When the pitch of the top feed dog is increased, the top feed dog extends to the front and rear.

○ Rear constant

When the pitch of the top feed dog is increased, locus extends to the front while the most retarded position of the top feed dog is constant.

○ Front constant

When the pitch of the top feed dog is increased, locus extends to the rear while the most advanced position of the top feed dog is constant.

Position of the motion of the top feed dog changes by changing the installing angle of θ° horizontal arm A ❶ and horizontal arm B ❷.

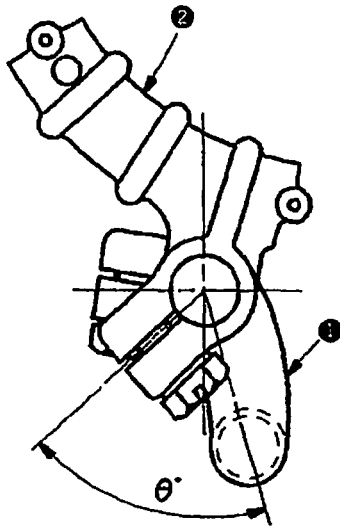

Horizontal feed link ❸ should not sway to the right or left.

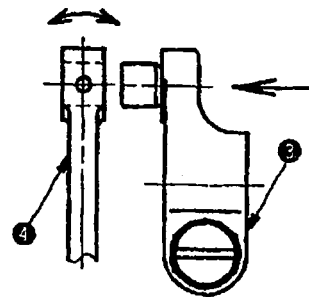

Adjustment Procedures	Results of Improper Adjustment
<p>○ Intermediate constant</p> <ol style="list-style-type: none"> 1) Make horizontal arm A ❶ in the state of temporary tightening, turn the handwheel and adjust the top feed dog to the position where it is desired to be constant. 2) At the position, tighten horizontal arm A ❶ at the position where the top feed dog does not move even when the top feed lever is moved. 3) Loosen horizontal arm C ❸ at the position where the top feed dog does not come in contact with the front or rear of the groove of the presser even when the pitch of the top feed dog is maximized. Then adjust the position of the horizontal shaft. <p>○ Rear constant</p> <ol style="list-style-type: none"> 1) Make horizontal arm A ❶ in the state of temporary tightening, turn the handwheel and adjust the top feed dog to the most retarded position. 2) At the position, tighten horizontal arm A ❶ at the position where the top feed dog does not move even when the top feed lever is moved. 3) Loosen horizontal arm C ❸ at the position where the top feed dog does not come in contact with the front or rear of the groove of the presser even when the pitch of the top feed dog is maximized. Then adjust the position of the horizontal shaft. <p>○ Front constant</p> <ol style="list-style-type: none"> 1) Make horizontal arm A ❶ in the state of temporary tightening, turn the handwheel and adjust the top feed dog to the most advanced position. 2) At the position, tighten horizontal arm A ❶ at the position where the top feed dog does not move even when the top feed lever is moved. 3) Loosen horizontal arm C ❸ at the position where the top feed dog does not come in contact with the front or rear of the groove of the presser even when the pitch of the top feed dog is maximized. Then adjust the position of the horizontal shaft. <p>(Caution) 1. Never loosen horizontal arm B ❷ since it keeps the thrust of the horizontal drive shaft.</p> <ol style="list-style-type: none"> 2. Set horizontal arm C ❸ to the position where horizontal feed link ❹ lightly moves without play. 3. Provide a clearance of 0.5 mm or more between the top feed dog and the groove of the presser when the pitch is maximized. 	<p>○ At the time of rear constant, the lowest point of the top feed dog is apt to be lowered when increasing the top feed stroke (clearance between top feed and bottom feed dogs is increased) and there is no effect for partial shirring. Use the top feed dog with intermediate constant or front constant.</p> <p>○ When the top feed dog is set to front constant, biting of cloth at the start of sewing is improved. However, a few loading is apt to occur at the overlapped section of knit fabric</p> <p>○ If the play between horizontal arm C ❸ and horizontal feed link ❹ is large, the return of the top feed adjusting lever is worsened and a forcible load is applied to the components.</p>

Standard Adjustment

(32) Position of the motion of the top feed dog

1. The position of motion is adjusted to rear constant for 50H and 60H series and MO-6900J, and to intermediate constant for other models at the time of delivery so that the best locus suitable to the purpose of use can be obtained.

2. Intermediate constant position at the time of delivery

The position of motion of the top feed dog other than that of 50H, 60H and MO-6900J is adjusted to the position where the top feed dog does not move even when the top feed lever is moved at the position where the timing is advanced by 19° from the upper dead point of needle.

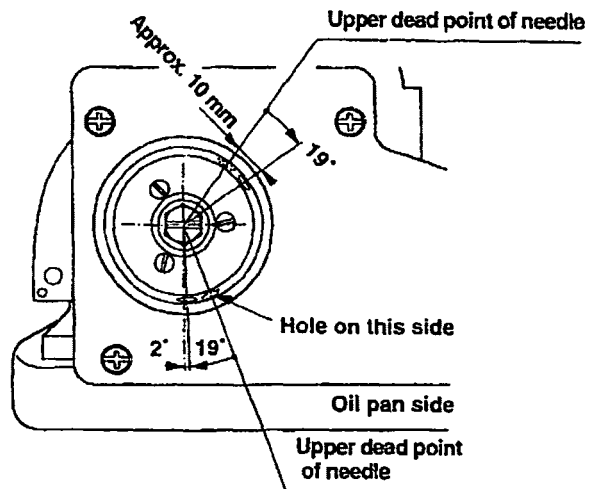

(33) Adjusting the feed bar guides A and B

When the play of the top feed dog in the lateral direction is excessively increased, the play can be removed by adjusting the feed bar guides A and B.

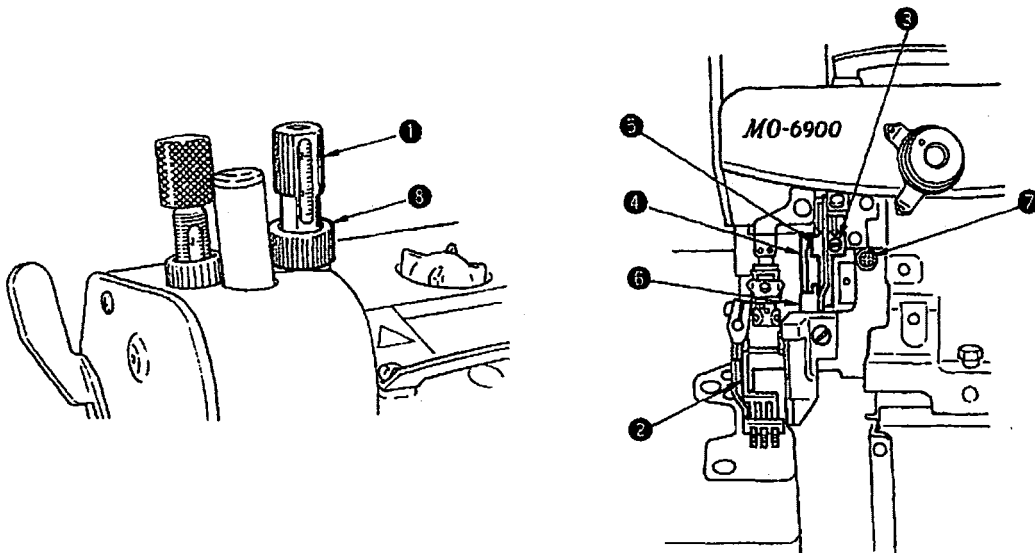

Adjustment Procedures	Results of Improper Adjustment
<ul style="list-style-type: none"> ○ Standard of the position where timing is advanced by 19° from the upper dead point of the needle 1) Timing is advanced by approximately 21° from the upper dead point of the needle at the position where the hole in the periphery of the handwheel faces just under. 	
<ul style="list-style-type: none"> 1) Remove top cover, locus cut base, exhaust slot support, and adjusting arm spring. 2) Loosen top presser adjusting screw ①, top presser adjusting screw nut ③, release top presser pressure, and check the play in the lateral direction of top feed dog ②. 3) Remove the needle thread tank, loosen setscrew ② in the feed bar guide B and temporarily tighten feed bar guide B ④ so that top feed bar ⑥ is put between feed bar guides B ④ and A ⑤. 4) Move top feed dog ② up or down and adjust so that top feed dog ② comes down by its weight and that the play in the lateral direction of top feed dog ② is kept down to a minimum. 5) When jar is produced at top feed dog ② and the top feed dog does not come down by its weight even after adjusting feed bar guide B ④, loosen setscrew ⑦ in the feed bar guide A and adjust feed bar guide A ⑤ at the same time. At this time, adjust the lateral position of top feed bar ⑥ to the position where top feed dog ② drops naturally when moving it up or down several times. 6) Securely tighten the respective setscrews and check that there is neither play nor jar. 7) Return adjusting arm spring, exhaust slot support, locus cut base and top cover to their home places. Refer to "(27) Vertical stroke of the top feed dog". <p>(Caution) When jar occurs between feed bar guide A ⑤ and B ④, and top feed bar ⑥, jumping of top feed dog ② will be caused. Adjust the top feed dog to such an extent that it comes down by its weight as mentioned above.</p>	<ul style="list-style-type: none"> ○ When the play in the lateral direction of top feed dog ② occurs, the top feed dog comes in contact with the presser and noise occurs or feed dog defect is apt to be put on cloth. ○ On the contrary, when torque occurs between feed bar guides A ⑤ and B ④, and top feed bar ⑥, inducement of the jumping phenomenon of top feed dog ② will be caused.

Standard Adjustment

(34) Adjusting the top feed dog pressure

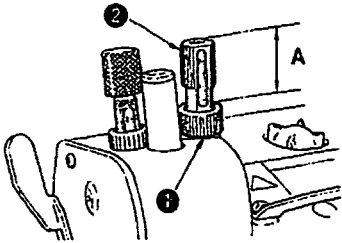

<Standard height of top presser adjusting screw>

	Dimension A	Vertical amount of top feed dog	Max. sewing speed
MO-6900R	24 to 25mm	Less than 6.5mm	7,000rpm
	20.5 to 21.5mm	6.5 to 8.5mm	7,000rpm
MO-6900J	20.5 to 21.5mm	8.5mm	6,000rpm

- Standard is the position where the top feed dog stops jumping and, when further the screw is tightened, sound becomes quiet and is stabilized when gradually tightening the screw from the lower pressure.
Besides, when using the top feed dog making low the top feed dog pressure, decrease the vertical amount of the top feed dog or decrease the sewing speed.
- Dimensions listed in the list are slightly increased values that can be guaranteed even when the vertical amount of top feed dog and sewing speed are in the most strict combination in the list. Accordingly, when using the machine by decreasing the vertical amount of the top feed dog or decreasing the sewing speed, use it with rather large value (top feed dog pressure is low) than dimensions A in the list.

(35) Lifting amount of the top feed dog (when operating the pedal)

The height of the top feed dog from the top surface of the throat plate when the pedal is depressed at the lowest point of the needle bar and the top feed dog goes up to the highest point is 9 ± 0.5 mm.

In case of MO-6900J, the height is 10.5 ± 0.5 mm.

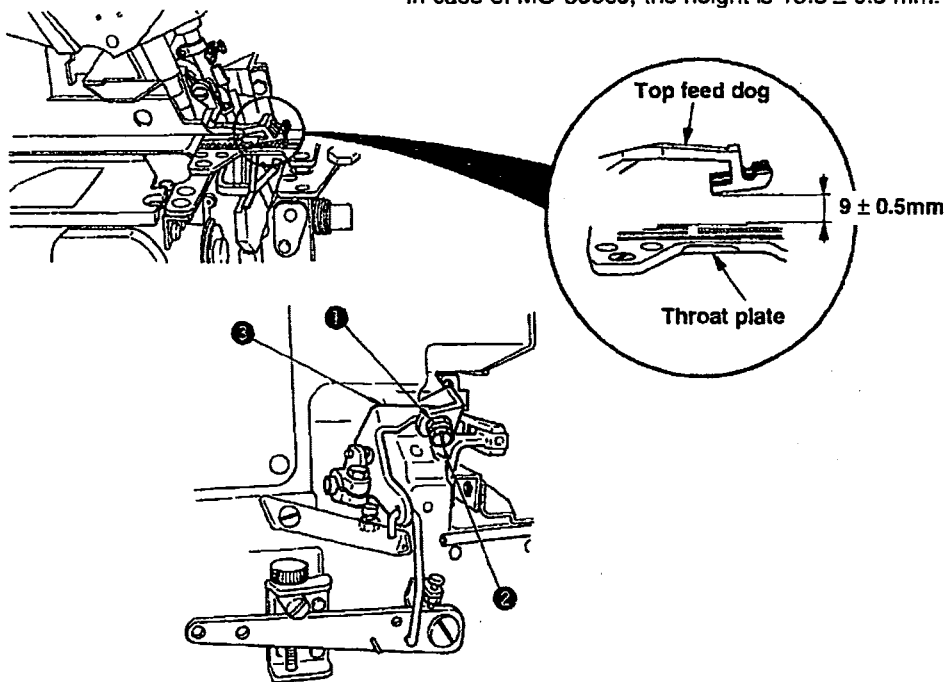

Adjustment Procedures	Results of Improper Adjustment
<p>Loosen top presser adjusting screw nut ❶, when tightening top presser adjusting screw ❷, the top feed dog pressure is increased and feed force is increased. After the adjustment, be sure to tighten top presser adjusting screw nut ❶.</p> <p>(Caution) When the top feed dog jumps and noise becomes large during using the sewing machine, tighten top presser adjusting screw ❷ until noise becomes small. When the machine is used for many hours while noise is excessively large, a forcible load is applied to other section. So, be careful.</p>	<ul style="list-style-type: none"> ○ When top feed dog pressure is excessively low Top feed dog jumps and noise becomes large. Feed force is decreased. ○ When top feed dog pressure is excessively high Feed dog defect is put on some materials. Unnecessary load is applied to the sewing machine and the sewing machine is influenced for the worse by it. Noise level is increased.
<p>1) Loosen lifter B stopper nut ❶ and turn lifter B stopper screw ❷ to adjust the lifting amount.</p> <p>2) After the adjustment, tighten lifter B stopper nut ❶.</p> <p><Checking after adjustment></p> <p>Play between the top end of lifter B stopper screw ❷ and presser lifting arm ❸ should be 0.5 to 1 mm when the top feed dog is brought to the lowest point (needle bar is at highest point).</p> <p>(Top end of the screw should be separated from presser lifting arm ❸ by 0.5 to 1 mm when pulling the lifter B with finger.)</p>	<ul style="list-style-type: none"> ○ When the lifting amount of the top feed dog is excessively high, contact occurs between vertical shaft and lifter B, and noise occurs when operating the sewing machine. ○ When the lifting amount of the top feed dog is excessively low, when entering cloth at the start of sewing heavy-weight materials, cloth may be not able to be entered at the top feed dog.

Standard Adjustment

(36) Height of the presser (pedal operation)

Height of the presser from the top surface of the throat plate when the presser goes up to the highest point

(Unit : mm)

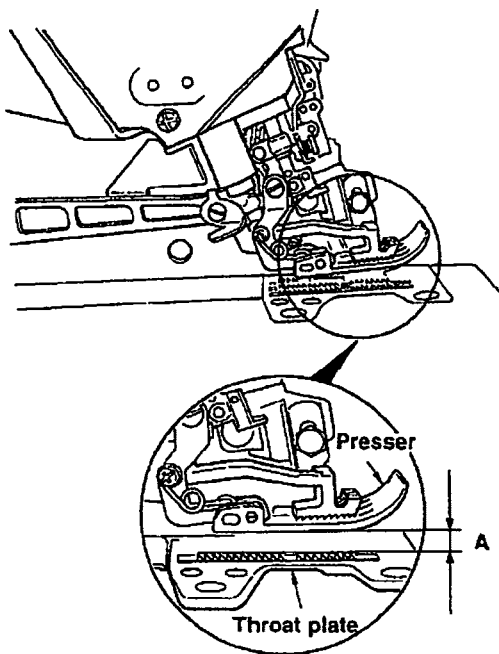

Model	Height of presser A (Max.)
MO -6904R -0Δ4 -300 0Δ6 -300 0Δ4 -500	7 ⁰ ₋₁
MO -6914R -BΔ4 -307 BΔ6 -307	6.5 ⁰ ₋₁
MO -6916R -DΔ4 -300 DΔ6 -300 FF6 -300 FΔ6 -50H FΔ6 -60H	5.5 ± 0.2 5.5 ± 0.2 5.5 ± 0.2 5 ± 0.2 5 ± 0.2
MO -6943R -1D6 -307	7 ⁰ ₋₁
MO -6914R -BΔ6 -337	6.5 ⁰ ₋₁
MO -6914R -ΔΔΔ-4ΔH	6.5 ⁰ ₋₁
Whole MO-6900J	8 ⁰ ₋₁

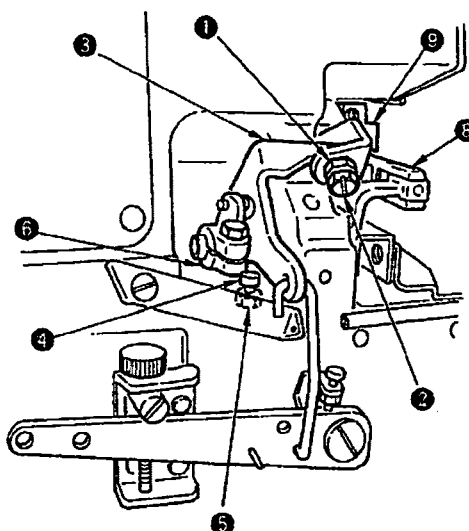
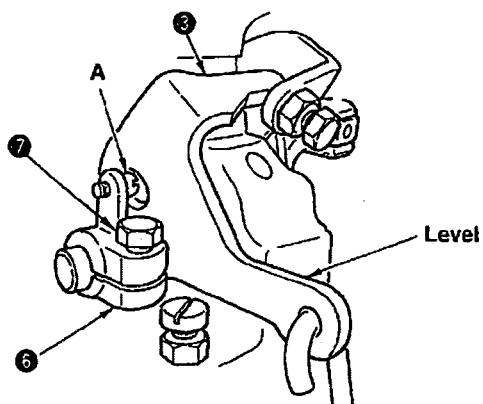

(Caution) When height A of the presser is adjusted at the time of operating the pedal, in connection with it, the adjustment value of the lifting amount of the top feed dog is changed. Check the lifting amount of the top feed dog after adjusting the height of the presser referring to "(35) Lifting amount of the top feed dog (when operating the pedal)"

Adjustment Procedures	Results of Improper Adjustment
<p>1) In the state that the presser pressure is applied, loosen presser turning lock nut ⑤ and adjust the height with presser lifter turning setscrew ④ so that the height in the list is obtained when operating the presser lifting pedal.</p> <p>At this time, check that there is no contact of the presser with upper looper, needle clamp, top feed dog, etc.</p> <p>(Caution) Adjust the height so that there is a slight clearance between presser arm ③ and presser arm stopper ⑨ when pedal is pressed and presser lifting arm ⑤ comes in contact with presser lifter turning setscrew ④ and stops.</p> <ul style="list-style-type: none"> ○ Adjust the height by the procedure below even when presser thrust arm ⑥ is removed. <p>1) Removing the thrust play of the presser shaft, temporarily tighten thrust arm clamping screw ⑦.</p> <p>Lower the presser by 1 to 3 mm from the throat plate with presser arm ③.</p> <p>2) Next, in the state of the aforementioned 1), fix presser lifter arm ⑤ with thrust arm clamping screw ⑦ so that presser lifter arm ⑤ is level and there is no clearance at section A.</p> <p>3) Adjust the lifting amount of the top feed dog with the aforementioned lifter B stopper screw ② and nut ①, and adjust the height of the presser with presser lifter turning setscrew ④ and nut ⑤ so that the height in the list is obtained.</p>	<ul style="list-style-type: none"> ○ When the height of the presser is excessively low, entering or taking out of cloth becomes hard. ○ When the height of the presser is excessively high, there is the possibility that the presser comes in contact with upper looper, needle clamp, etc.

Standard Adjustment

(37) Lifting amount of the top feed dog (when the presser lifting lever is operated)

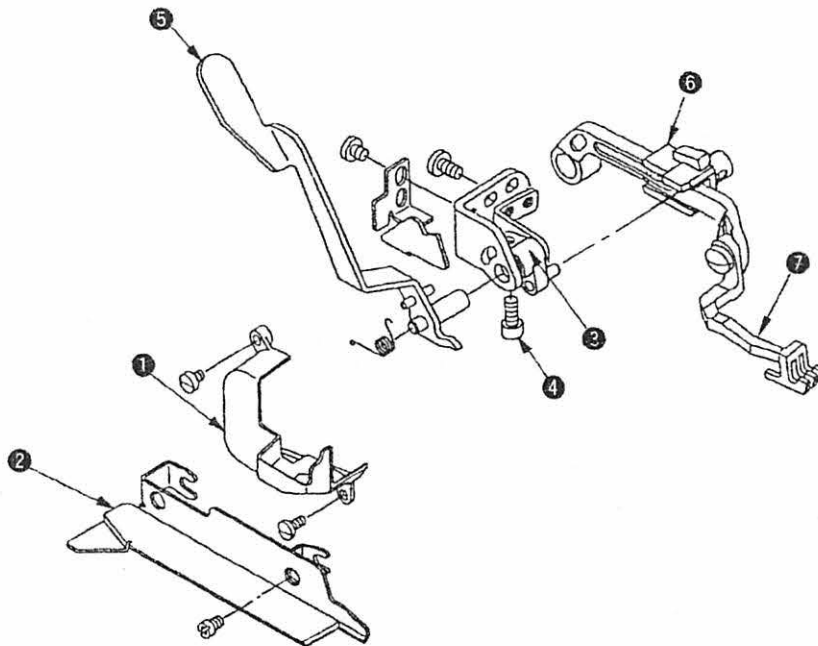
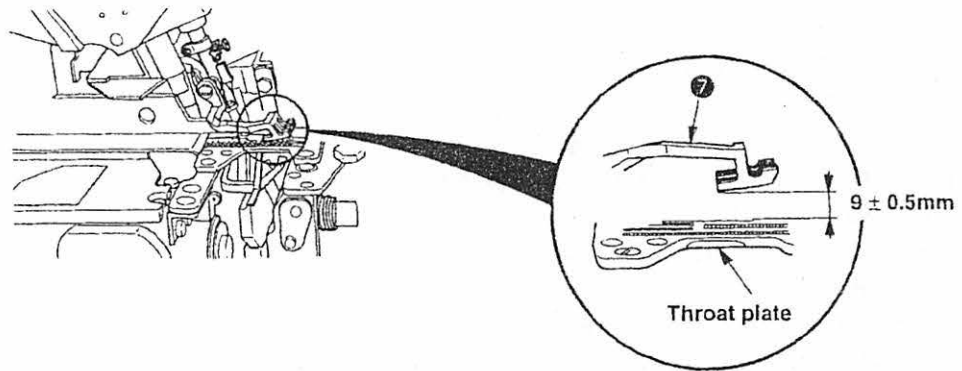

It is the standard that the height from the top surface of the throat plate is 9 ± 0.5 mm when presser lifting lever ⑤ is pressed at the lowest point of the needle bar and top feed dog ⑦ goes up to the highest point. MO-6900J : 10.5 ± 0.5 mm



Adjustment Procedures	Results of Improper Adjustment
<p>1) Remove cloth base side cover ② and top feed cover ①.</p> <p>2) Bring the needle bar to the lowest point of its stroke and keep top feed dog ⑦ at the height of 9 ± 0.5 mm (MO-6900J : 10.5 ± 0.5 mm) from the top surface of the throat plate. (Insert the spacer between the throat plate and top feed dog ⑦.)</p> <p>3) Loosen clamping screw ④ of lifter A ③.</p> <p>4) Press presser lifting lever ⑤ until it will go no further and turn it. In this state, turn lifter A ③ and strike the pin section to the eaves section of top feed square block ⑥. Then tighten clamping screw ④ of lifter A ③.</p> <p>(Caution) In the state that presser lifting lever ⑤ is returned, check that there is a clearance between the pin of lifter A ③ and the eaves section of top feed square block ⑥.</p> <p>5) Return top feed cover ① and cloth base side cover ② to their home positions.</p>	<ul style="list-style-type: none"> ○ When the lifting amount of top feed dog ⑦ is excessively high, contact of top feed square block ⑥ with the pin section of lifter A ③ occurs at the time of operation and something is wrong with the machine. ○ When the lifting amount of top feed dog ⑦ is excessively low, cloth or the presser becomes hard to be removed at the thick section such as overlapped section or the like.

Standard Adjustment

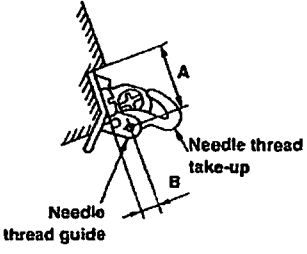
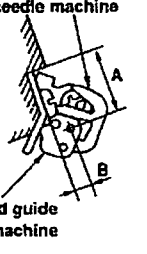
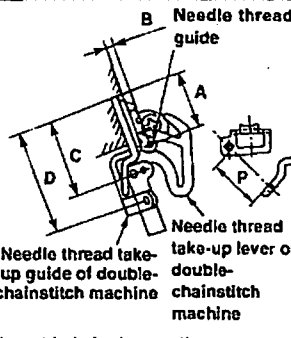
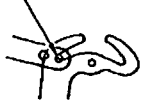
(38) Position of the thread guides and the looper thread take-ups

MO-6△04S (R)	MO-6△14S (R)	MO-6△16S (R)
 <p style="text-align: center;">Needle thread take-up Needle thread guide</p>	<p style="text-align: center;">Needle thread take-up lever of 2-needle machine</p>  <p style="text-align: center;">Needle thread guide of 2-needle machine</p>	 <p style="text-align: center;">Needle thread take-up lever of double-chainstitch machine Needle thread take-up guide of double-chainstitch machine</p>
<p>The thread hole in the needle thread guide and the hooked portion of the needle thread take-up are in the position where 2/3 of the hole in the needle thread guide can be observed.</p> 	<p>The thread hole in the needle thread guide and the hooked portion of the needle thread take-up are in the position where 2/3 of the hole in the needle thread guide can be observed.</p> 	<p>The thread hole in the needle thread guide and the hooked portion of the needle thread take-up are in the position where 2/3 of the hole in the needle thread guide can be observed.</p>  <p>The thread hole in the double-chainstitch needle thread guide and the hooked portion of the needle thread take-up are in the position where the entire hole in the needle thread guide can be observed.</p>

(Caution) The needle thread take-up shall be positioned at the lower dead point.

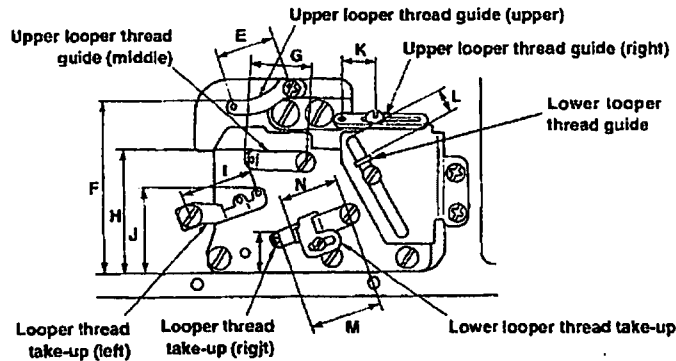

(Unit : mm)

Symbol	MO-6△04S (R) (Standard)		MO-6△14S (R) (Standard)		MO-6△16S (R) (Standard)		MO-6△16S (R) (50H, 60H)	MO-6△05S (R) (Hemming)		MO-6△04S (R) (Soft chain)
	General thread	Woolly thread	General thread	Woolly thread	General thread	Woolly thread	General thread	General thread	Woolly thread	General thread
A	15.8	←	←	←	←	←	←	←	←	13.5
B	3.4	←	←	←	1.8	←	2.6	3.4	←	2.1
C	-	-	-	-	21.5	←	2.3	-	-	-
D	-	-	-	-	30.5	←	24.5	-	-	-
E	22	←	←	←	←	←	←	←	←	←
F	65	←	←	←	←	←	←	←	←	←
G	17.5	←	←	←	←	←	←	←	←	←
H	43.5	←	←	←	←	←	←	40.5	←	43.5
I	26.5	←	←	←	←	←	←	24	←	26.5
J	38	41	38	←	34	36	34	38	42	43.5
K	15	←	12	15	12	15	12	12	←	14
L	6.5	←	10	←	6.5	←	←	24	34	←
M	29	←	←	←	27.5	←	←	29	←	26.5
N	27	21	23	←	20	←	19	24	←	19
O	11	←	←	←	←	←	←	12	←	9.5
P	-	-	-	-	16	←	12.8	-	-	-

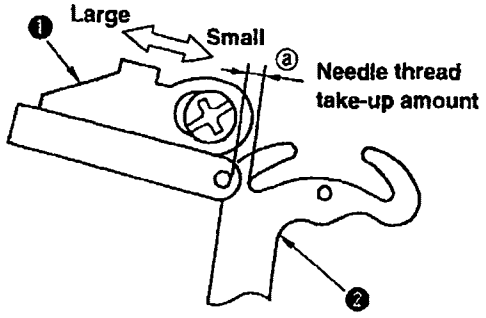
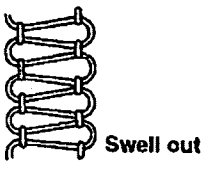
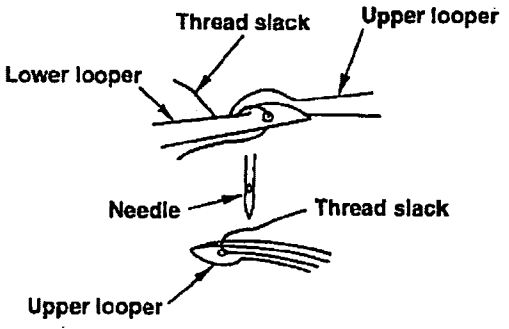
Adjustment Procedures	Results of Improper Adjustment
<p>1) Perform the adjustment by the setscrews. Position of the needle thread guide ① and needle thread take up ② lever is a very important decisive factor when making soft chains since the needle thread take-up amount is increased in this case. So, carefully position these parts.</p>  <p>The diagram shows a side view of the needle thread take-up mechanism. It features a needle thread guide (1) and a needle thread take-up lever (2). A double-headed arrow indicates the range of adjustment from 'Large' to 'Small'. The text 'Needle thread take-up amount' is written next to the lever.</p> <p>2) Set distance I a little smaller when using synthetic thread or the like which tends to form stitches swelling out of the cloth edge. A smaller I is effective for preventing stitch skipping.</p>  <p>The diagram shows a vertical column of stitches that are wider at the top and bottom, labeled 'Swell out'.</p> <p>3) Distance J is related to the vertical knotting point of the upper and lower looper threads. Set this distance larger for wooly thread, and set it smaller for thin thread which is likely to cause stitch skipping.</p> <p>4) It is desirable to set distance K larger for stretchy threads such as wooly thread.</p> <p>5) Set distance L a little larger when making blind hemming soft chain stitches.</p> <p>6) Set distance N a little smaller for blind hemming or making soft chain stitches.</p> <p>7) Set distance O larger if stitch skipping occurs due to looper thread slack. Set it smaller for better appearance and touch of produced stitches when wooly thread is used.</p>	<ul style="list-style-type: none"> ○ Distance ② When set smaller, better tightness of needle thread stitches will be obtained. When set larger, loose needle thread stitches will result. ○ Distance E, F and H exert least influence on stitch formation, however, improper setting of these distances will cause contact between the moving parts. ○ Distance J When set larger, the amount of the upper looper thread will be increased. When set smaller, the amount of the upper looper thread will be decreased. ○ Distance K When set larger, the amount of the upper looper thread will be increased. When set smaller, the amount of the upper looper thread will be decreased. ○ Distance L When set larger, the amount of the upper looper thread will be increased. When set smaller, the amount of the upper looper thread will be decreased. ○ Distance N When set larger, the amount of the upper looper thread will be increased. When set smaller, the amount of the upper looper thread will be decreased. ○ Distance I When set larger, the amount of the upper and lower looper threads will be increased. When set smaller, the amount of the upper and lower looper threads will be decreased. ○ Distance O When set larger, the amount of the upper and lower looper threads will be decreased. When set smaller, the amount of the upper and lower looper threads will be increased.
 <p>The diagram illustrates thread slack in two stages. The top part shows the 'Lower looper' and 'Upper looper' threads with 'Thread slack' between them. The bottom part shows the 'Needle' and 'Upper looper' threads with 'Thread slack' between them.</p>	

Standard Adjustment

(39) Adjusting soft chain making mechanism

1) Replacing the parts with those exclusively designed for making soft chains

- ① Needle thread presser plate C 12112504
- ② Driving cam 12112603
- ③ Needle thread presser spring B 12112702
- ④ Throat plate (only for 1-needle overlock machine)
overlock machine)
- 0D4-300 R4200J6DD0A

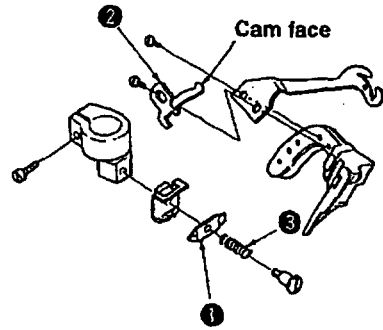

2) Adjustment value

- ① Needle thread guide and needle thread take-up lever

Adjust the needle thread guide to increase the needle thread feeding amount when the needle bar is in the lowest dead point of its stroke.

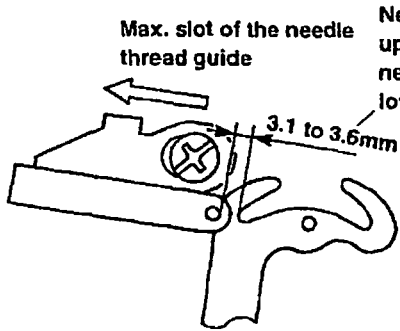

(04 1-needle overlock machine)

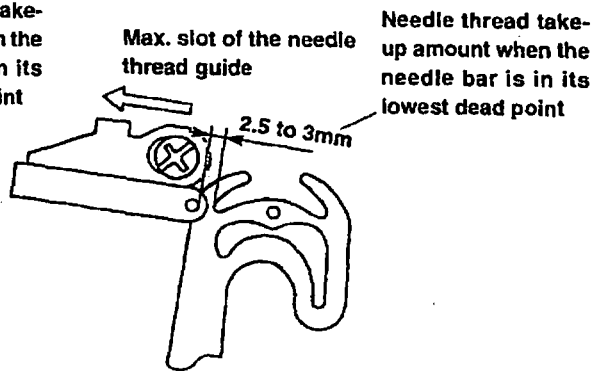

(16 Safely stitch machine)

- ② Adjust the rising amount of needle thread presser plate C.

Adjust the rising amount of needle thread presser plate C ① to 0.6 to 1 mm (max.) by moving driving cam ② to the right and left within the slot.

Rising amount : 0.6 to 1 mm (max.)

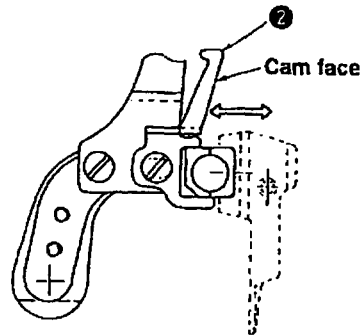
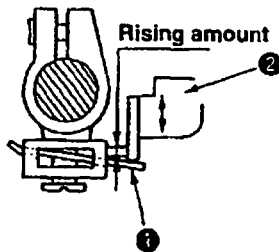

3) Important points in adjustment

- ① Increase the thread take-up amount of the needle thread take-up lever.
Refer to the adjustment values related to the needle thread guide and needle thread take-up lever.
- ② Reduce the feed of the looper threads. (Mainly lower looper thread)
Set J, K, L and M for the soft chain distances.
Fine adjustment of J and M is required to produce even stitches.
- ③ Adjust the thread tension while checking the appearance and touch of the stitches produced.
 - 1) Minimize the needle thread tension as far as satisfactory tightness of needle thread stitches is obtained.
 - 2) Increase the upper looper thread tension as much as possible.
- ④ If the chain-off thread does not stretch satisfactorily, and if it is not satisfied, proceed with the following.
 - 1) Increase the upper looper thread tension.
 - 2) Further increase distances J and K.
 - 3) Further increase the upper looper thread tension.
 - 4) Increase the lower looper thread tension to a maximum as far as good tightness of needle thread stitches is maintained.
 - 5) Increase the thread take-up amount. If the needle thread is poorly tensed, increase the needle thread tension.
- ⑤ Fine adjustment for producing stitches with better appearance and touch
 - 1) If the knotting point varies at high or low sewing speed, slightly reduce L, and increase the lower looper thread tension.
 - 2) If a knot is made at a high point, increase J and I.
 - 3) If the needle thread is likely to break, decrease the thread take-up amount and lower the needle thread tension.
- ⑥ Pay attention to the following
 - 1) Minimize the needle thread tension as far as satisfactory tightness of needle thread stitches is obtained.
 - 2) The knot of upper and lower looper threads should be made near the upper edge of a material.
 - 3) Minimize the lower looper thread tension as far as even stitches are maintained.
 - 4) For a safety stitch machine, adjust the soft chain making mechanism so that uniform chain-off thread is produced during double-chain stitching and overlocking.

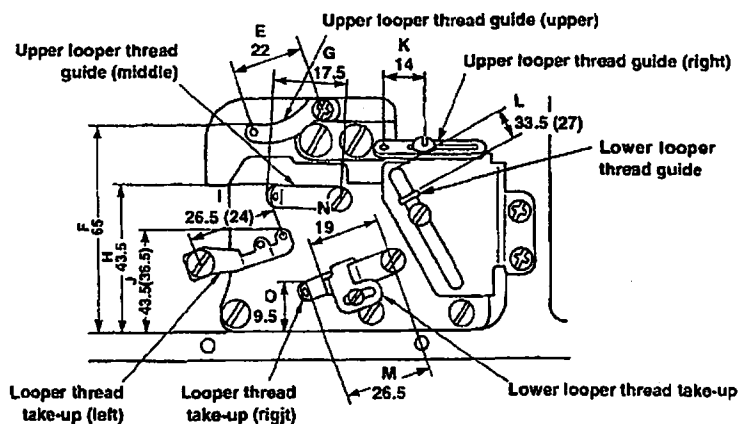

The value given in () parentheses is the adjustment value for the safety stitch machine. (Unit : mm)

Soft chain stitches



When the chain-off thread is pulled.



Looper thread should not be loosened and stretch well

Standard stitches





When the chain-off thread is pulled.



The looper thread loosens

Standard Adjustment

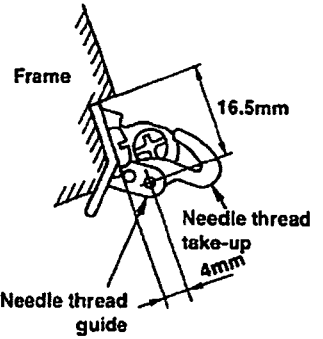
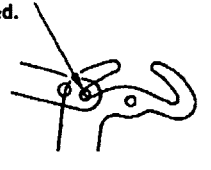
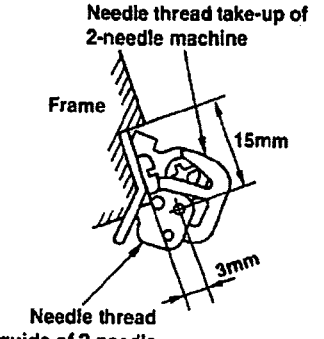
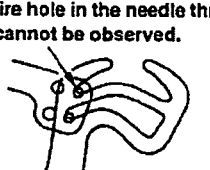
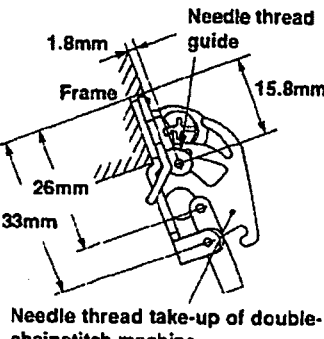
(40) Position of the thread guides and the looper thread take-ups of MO-6900G(J)

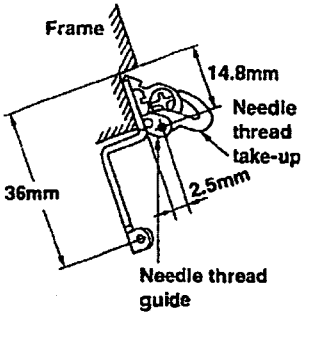
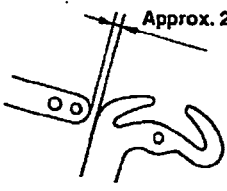
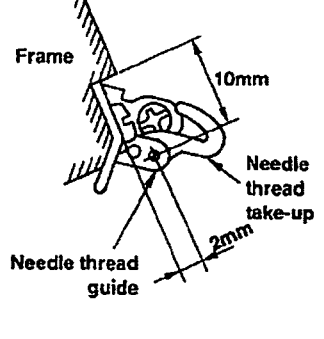
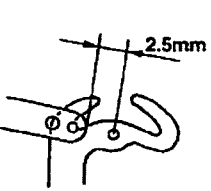
MO-6904G (J)	MO-6914G (J)	MO-6916G (J)
 <p>The thread hole in the needle thread guide and the hooked portion of the needle thread take-up are in the position where 1/2 to the entire hole in the needle thread guide cannot be observed.</p> 	<p style="text-align: center;">Needle thread take-up of 2-needle machine</p>  <p>The thread hole in the needle thread guide and the hooked portion of the needle thread take-up are in the position where 1/2 to the entire hole in the needle thread guide cannot be observed.</p> 	<p style="text-align: center;">Needle thread take-up of double-chainstitch machine</p>  <p>The thread hole in the needle thread guide and the hooked portion of the needle thread take-up are in the position where 1/2 to the entire hole in the needle thread guide cannot be observed.</p> 
MO-6903G	MO-6905G	
 <p style="text-align: center;">Approx. 2 mm</p> 	 <p style="text-align: center;">2.5mm</p> 	

(Caution) The needle thread take-up shall be positioned at the lower dead point.

MO-6904G (J), 6914G (J), 6916G (J)

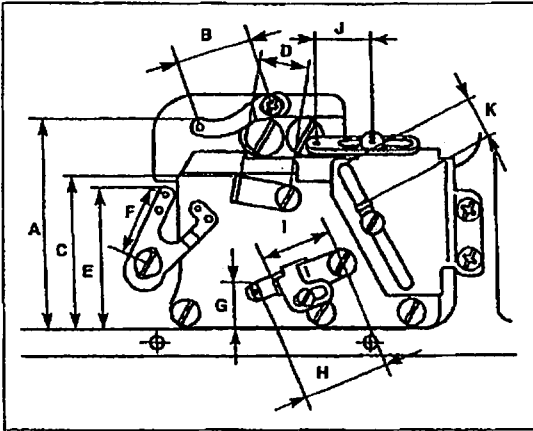

MO-6905G

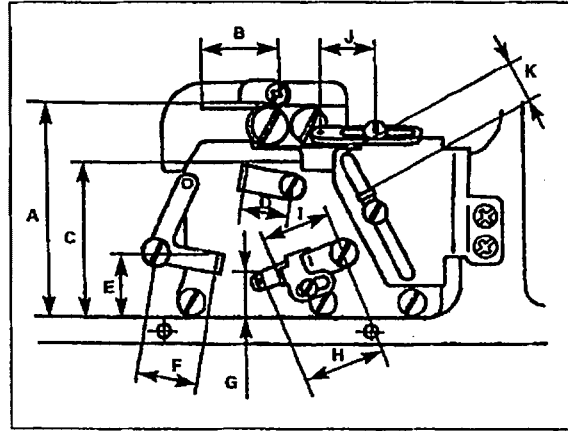

MO-6903G

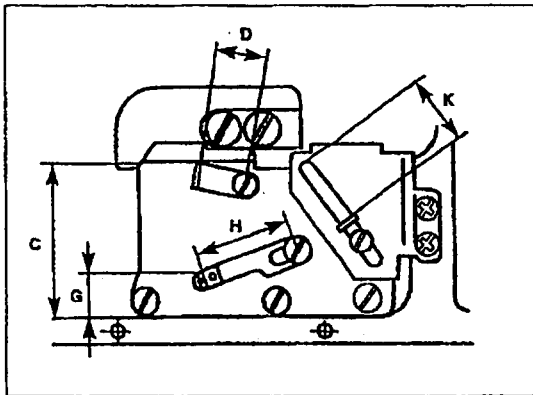

(Caution) The upper looper thread-take-up (right) and the looper thread take-up (left) shall be positioned at the extreme right point of the upper looper.

(Unit : mm)

Position	MO-6904G(J)-0F6-700	MO-6914G(J)-CH6-700	MO-6916G(J)-F△6-700	MO-6905G-0M6-7△0	MO-6903G-0N6-3D1
A	70	←	←	65	-
B	22	←	←	20	-
C	48	-	←	46	52
D	18	←	←	←	←
E	43	←	←	22	-
F	22	←	←	18	-
G	11	←	←	16	13
H	27	←	←	26	31
I	23	←	←	20	-
J	18	←	←	10	-
K	17	←	←	←	27

4. ADDITIONAL INFORMATION AND PRECAUTIONS

(1) Thread tension

1) Strength of tension spring

Part No.	Color	Natural length (mm)	Operating length (mm)	Weight required to compress spring to working length
11550100	Purple	19.5 mm	11.5 mm	8.92±0.49N (910 ± 50 g)
11550209	Green	19.5 mm	11.5 mm	6.27±0.49N (640 ± 50 g)
13137807	Red	19.5 mm	11.5 mm	4.21±0.49N (430 ± 50 g)
13138508	Yellow	17.8 mm	9.8 mm	3.14±0.34N (320 ± 35 g)
13138805	Blue	17.3 mm	9.3 mm	1.47±0.20N (150 ± 20 g)
B3121804000	Gray	13.8 mm	5.8 mm	1.47±0.20N (150 ± 20 g)

2) Springs used for each model.

Model	Where to use	Needle thread	Double-chainstitch needle thread	Upper looper thread	Lower looper thread
MO-6Δ04S(R) series		Red	—	Yellow	Blue
MO-6Δ05S series		Yellow	—	Blue	Yellow
MO-6Δ12S series		Red Yellow	—	Yellow	Blue
MO-6Δ14S(R) series		Red Yellow	—	Blue	Yellow
MO-6Δ16S(R)-ΔΔΔ-ΔΔΔ(4ΔΔ or lower)		Red	Yellow	Yellow	Blue
MO-6Δ16S(R)-ΔΔΔ-50Δ		Red	Red	Blue	Yellow
MO-6Δ16S(R)-ΔΔΔ-60H		Green	Green	Blue	Yellow
MO-6Δ43S(R) series		Red Red	Yellow	Blue	Yellow
MO-6Δ45S series		—	Red Red	—	—
MO-6903G-0N6-3D1		Blue	—	—	Blue
MO-6904G(J)-0F6-700		Purple	—	Yellow	Red
MO-6905G-0M6-7Δ0		Yellow	—	Yellow	Purple
MO-6914G(J)-CH6-700		Red	Yellow	Yellow	Red
MO-6916G(J)-FΔ6-700		Purple	Green	Yellow	Red

(2) Upper looper

Use a proper upper looper in accordance with the needle No. When ordering, refer to the Parts List. The numbers shown in frame in the table below are engraved markers. In addition, the letters in () parentheses are the kinds of the needles.

Parts Nos. with an asterisk * are factory-installed on the standard machine heads at the time of delivery.

Model	Nos. engraved on upper looper	Needle No. (kind)
6Δ04S(R) series	*1188 <input type="checkbox"/> 81	#9 #11 #14
6Δ16S(R) series	1199 <input type="checkbox"/> 92	#14 #16 #18
	1217 <input type="checkbox"/> 82	#21
6Δ14S(R) series	*1217 <input type="checkbox"/> 60	
6903G-0N6-3D1	<input type="checkbox"/> 120148	#16 (DOx5)
6904G(J)-0F6-700	<input type="checkbox"/> 123835	#21 (DOx5)
6905G-0M6-7Δ0	<input type="checkbox"/> 123837	#24 (DCx1)
6914G(J)-CH6-700	<input type="checkbox"/> 123836	#18 (DOx5)
6916G(J)-FΔ6-700	<input type="checkbox"/> 123835	#21 (DOx5)

(3) Center-to-center distance of the upper looper holder

The center-to-center distance of upper looper holder ❶.

(Unit : mm)

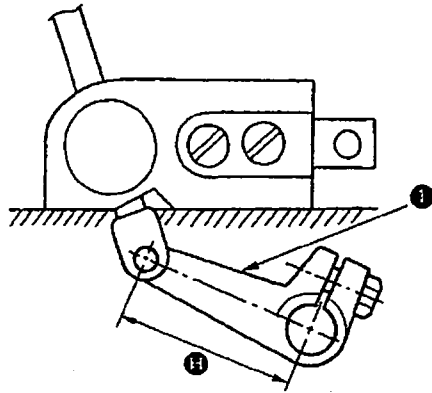

Model	Center-to-center distance ❶
MO- 6Δ04S(R) -ΔΔΔ -ΔΔΔ 6Δ05S -ΔΔΔ -ΔΔ0	38
MO- 6Δ04S(R) -0D4 to 0E4 4ΔH 0F6 50H	39
MO- 6Δ12S -CE4 -40H	38
MO- 6Δ12S -DΔΔ -ΔΔΔ	39
MO- 6Δ14S(R) -ΔΔΔ -ΔΔΔ	39
MO- 6Δ16S(R) -ΔΔΔ -ΔΔ0	38
MO- 6Δ16S(R) BE4 DDΔ to FFΔ- 4ΔH 5ΔH	39
MO- 6943R -ΔΔΔ -ΔΔ7	39
MO- 6Δ43S -ΔΔΔ -40H	39
MO- 6903G -0N6 -3D1	*39
MO- 6904G(J) -0F6 -700	37.5
MO- 6905G -0M6 700 7E0	*39
MO- 6914G(J) -CH6 -700	37.5
MO- 6916G (J) FH6 FF6 -700	37.5

(Caution) * (asterisk) marks are exclusive for to the MO-6900G(J). They are not common to the MO-6000S(R) series.

(4) Caution in assembly

1) Application of sealant

- ❶ Setscrew of the throat plate base (B) retainer ❷ (JUKI seal)
Apply the sealant only to the right setscrew.

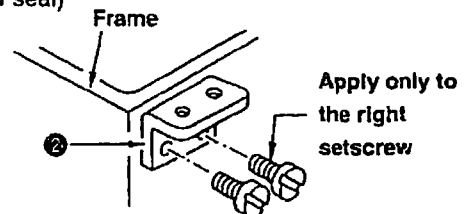

- ❷ Bottom surface of the upper looper guide support ❸ (Three-bond 1104)
Apply the sealant to the bottom surface of the upper looper guide support ❸, which contacts with the frame surface.

- ❸ After assembling the front edge of the upper looper guide support ❹ (Three-bond 1212), apply the sealant to the gap of the contact surface between the frame and the upper looper guide support ❸ ([] section in the illustration).

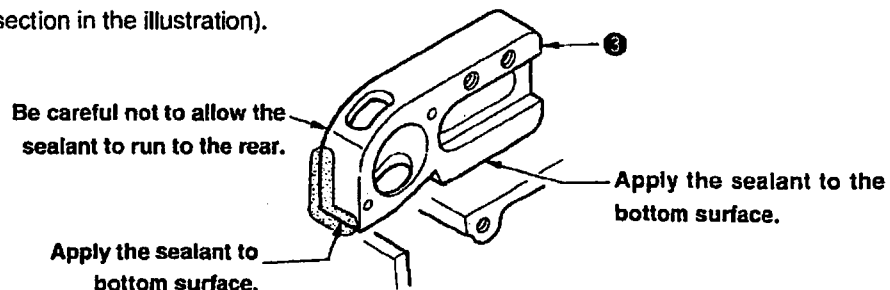

④ Portion of the setscrews of the dust-proof rubber case (JUKI seal)

Apply the sealant to the oil shield case setscrew ① (1 pc.) and the dust-proof rubber case ② setscrews (4 pcs.)

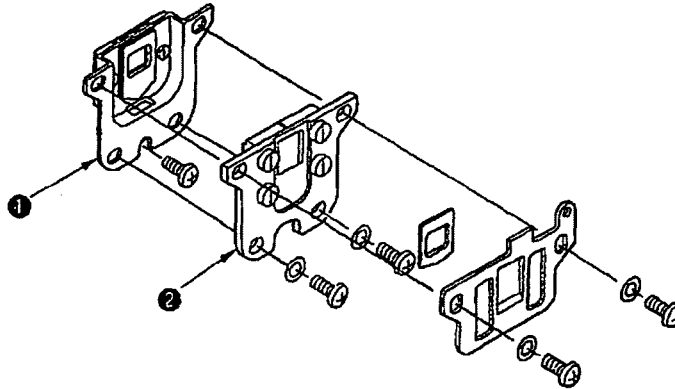

⑤ Oil shield plate assembly (JUKI seal)

Apply the sealant to the inside of the oil shield plate ③.

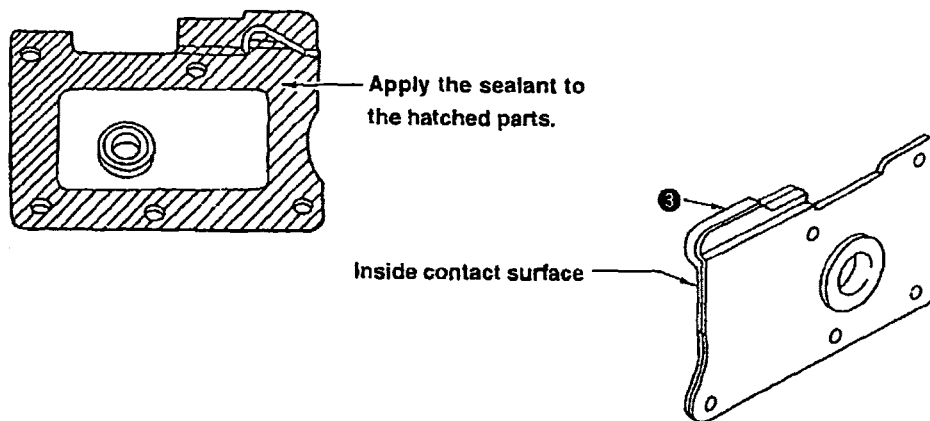

⑥ Portion of the feed mechanism cover (Three-bond 1212)

Apply the sealant to the rear face of the feed mechanism cover, the top surface of the oil shield plate, the oil shield rubber support plate, the top surface of the oil shield case, and the hatched parts on the top surface of the feed bar presser.

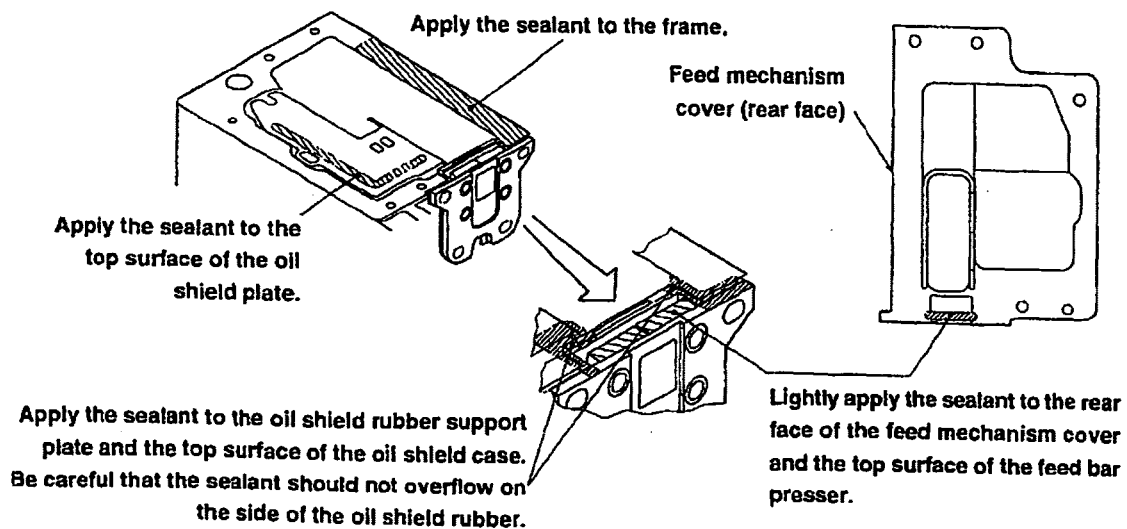

⑦ Various sealants

Maker's name	Part No.
Three Bond	1104D *
Three Bond	1104
Three Bond	1212

* : It is commonly called "JUKI seal".

JUKI exclusive part Nos. of the above 3 kinds of the sealants are not set.

2) Precautions to be taken with respect to the lubricating components

Feed bar components

- Be careful of the orientation of the oil shield rubber ④ and the dust-proof rubber ⑤.

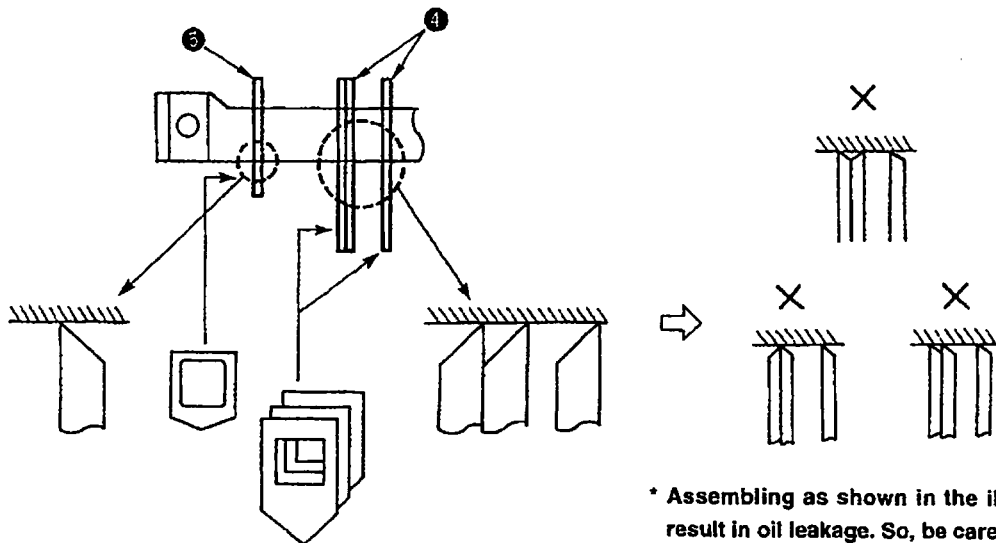

- Assemble the feed bar presser ⑥ and the dust-proof rubber case ② so that their top faces are flush with the frame plane on which the feed mechanism cover is installed.
- Do not loosen the screws in feed bar presser ⑥ unless it is necessary. The clearance between the feed bar presser and the feed bar and the contact with each other are important.

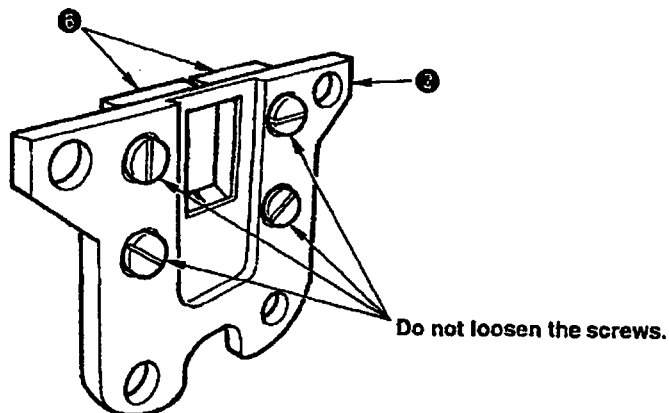

(5) Kinds of motor pulleys, belts and frame support plate bolts

1) Motor pulleys and belts

MO-6△00S(R)

Sewing speed of sewing machine (rpm)	50 Hz			60 Hz		
	Outside diameter of motor pulley mm (Effective diameter mm)	V-belt		Outside diameter of motor pulley mm (Effective diameter mm)	V-belt	
		Semi-sunken type mm (inch)	Fully-sunken type mm (inch)		Semi-sunken type mm (inch)	Fully-sunken type mm (inch)
8500	160 (155)	1016 (40)	914 (36)	135 (130)	965 (38)	864 (34)
8000	150 (145)	1016 (40)	864 (34)	125 (120)	965 (38)	813 (32)
7500	140 (135)	965 (38)	864 (34)	120 (115)	965 (38)	813 (32)
7000	130 (125)	965 (38)	864 (34)	110 (105)	914 (36)	813 (32)
6500	120 (115)	965 (38)	813 (32)	100 (95)	914 (36)	813 (32)
6000	110 (105)	914 (36)	813 (32)	95 (90)	889 (35)	762 (30)
5500	100 (95)	914 (36)	813 (32)	85 (80)	889 (35)	762 (30)
5000	90 (85)	889 (35)	762 (30)	80 (75)	864 (34)	762 (30)
4500	85 (80)	889 (35)	762 (30)	70 (65)	864 (34)	762 (30)
4000	75 (70)	864 (34)	762 (30)	60 (55)	864 (34)	737 (29)

MO-6900G(J)

Sewing speed of sewing machine (rpm)	50 Hz			60 Hz		
	Outside diameter of motor pulley mm (Effective diameter mm)	V-belt		Outside diameter of motor pulley mm (Effective diameter mm)	V-belt	
		Semi-sunken type mm (inch)	Fully-sunken type mm (inch)		Semi-sunken type mm (inch)	Fully-sunken type mm (inch)
6000	125 (120)	965 (38)	864 (34)	105 (100)	914 (36)	838 (33)
5500	115 (110)	940 (37)	838 (33)	95 (90)	914 (36)	813 (32)
5000	105 (100)	914 (36)	838 (33)	85 (80)	889 (35)	787 (31)
4500	95 (90)	914 (36)	813 (32)	80 (75)	889 (35)	787 (31)
4000	85 (80)	889 (35)	787 (31)	70 (65)	889 (35)	787 (31)

- * Use a motor of 3/4 HP (550 W) when the sewing machine runs at 7,000 rpm or higher speed.
Use a motor of 1/2 HP (400 W) when the sewing machine runs at a speed lower than 7,000 rpm.

(Caution) If a motor of less than 400W is used, in the low temperature area, viscosity of oil increases and the sewing speed may not increase or the sewing machine may fail to run in some cases.

* Part No. of motor pulley

MTKP0xxx000 (Enter the effective diameter to "xxx.")

If the outside diameter of the motor pulley is 150 mm, the effective pulley will be 145.

.....So, the part No. will be MTKP0145000.

If the outside diameter of the motor pulley is 90 mm, the effective pulley will be 085.

.....So, the part No. will be MTKP0085000.

* Part No. of belt

MTJVM00xx00 (Enter a number that shows the belt length to "xx.")

If the belt length is 1016 mm (40 inches), enter "40" to "xx."

.....So, the part No. will be MTJVM004000.

If the belt length is 889 mm (35 inches), enter "35" to "xx."

.....So, the part No. will be MTJVM003500.

2) Pat No. of frame support plate bolt

① Semi-sunken type

Support plate bolt (A)	13155007	x4
Locknut	NS6240630SE	x4
Washer	WP1002036SE	x4
Spring washer	WS1002560KR	x4

② Fully-sunken type

Support plate bolt (C)	13155106	x2
Support plate bolt (D)	13155205	x2
Locknut	NS6240630SE	x12
Washer	WP1002036SE	x12
Spring washer	WS1002560KR	x4

Difference of support plate bolts (A), (C) and (D)

Entire length under the neck and length of threaded part

(Unit : mm)

	Entire length	Length of threaded part
Support plate bolt (A)	69	39
Support plate bolt (C)	137	107
Support plate bolt (D)	149	119

Support plate bolt (A)

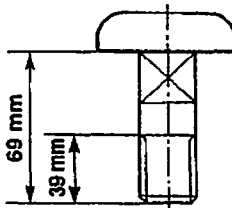

Support plate bolt (C)

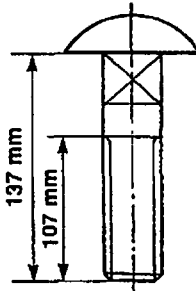

Support plate bolt (D)

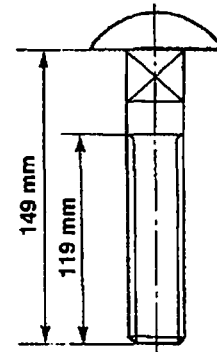

(6) Inspection and replacement of the cartridge filter

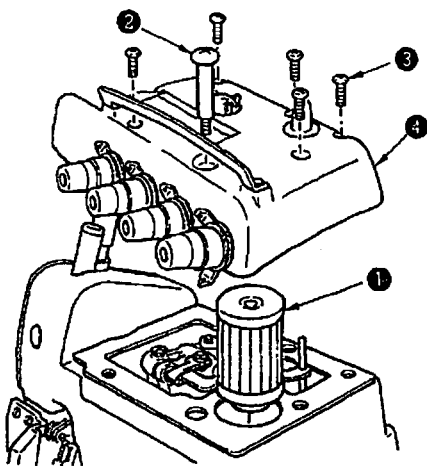

1. When the sewing machine is used for many hours, cartridge filter ① may be clogged with dust.

When this state continues, oil is not fed through cartridge filter ① and abnormal worn-out or seizure of the sewing machine will be caused.

* Normally, be sure to check cartridge filter ① every 6 months, and clean or replace it.

2. Inspecting/replacing procedure

- 1) First, remove drain screw ②.
- 2) Remove setscrews ③ and remove upper cover ④ toward right above.

(Caution) When upper cover ④ is moved in the lateral direction, the oil amount indicating rod or the filter may be damaged.

- 3) Remove and inspect cartridge filter ①. If cartridge filter ① is clogged with dust, clean it or replace it with a new one.
- 4) Insert cartridge filter ① in place and install upper cover ④ with setscrews ③.

* Part No. of cartridge filter : 11843208

This image shows a blank sheet of lined paper, likely from a notebook or a page from a binder. The paper is white and features a vertical margin line on the left side. The main body of the page is ruled with horizontal lines, creating a series of writing rows. The lines are evenly spaced and extend across the width of the page. The top and bottom corners of the page are rounded. There is no text or other markings on the page.

6. TROUBLES AND CORRECTIVE MEASURES

Trouble	Case (1)	Case(2)	Check and Corrective measures	Page
1. Needle thread breakage	Threading	The thread is entangled with the thread guide, or the machine head has been incorrectly threaded.	Refer to the threading diagram.	22
	Thread path	Scratches, burrs or rust on the pawls or needle holes of the throat plate, stitch tongue, lower looper, double chain looper, needle thread take-up, needle thread presser spring, thread guide, or tension discs causes friction.	Remove such scratches, burrs, etc. and perform thread path finishing. Replace major components such as looper, which have been deformed, causing thread breakage.	
	Needle guard	The needle hits the needle guard intensely, and sharp edges are produced on them, causing thread breakage.	Replace the needle and needle guard if they have worn,	
	Needle	The needle is too thin for the thread.	Replace the needle by a proper one.	
	Needle heat	The needle gets very hot, depending on the type of materials, number of piles and sewing speed, and causes the thread to burn and break.	Use a thinner needle. Reduce the sewing speed. Use the needle cooler. Use an S-point needle or needle for synthetic thread.	
	Thread	The thread is weak because of its poor quality.	Replace the thread by one with good quality.	
	Thread tension	The thread tension is too high.	Reduce the thread tension. Check whether the needle thread take-up guide and needle thread guide are positioned too high, causing such excessive thread tension.	
	Contact	The double chain looper or lower looper has been improperly positioned and strikes the feed dog or throat plate.	Properly position the double chain looper or lower looper.	12, 20
	Double thread hooking (only for double chain stitch)	Poor drawing up of the needle thread causes the looper to catch it again.	Increase the needle thread tension. Properly position the thread cam. Properly position the double chainstitch thread guide.	32
	Defective double chain-off thread (only for double chain stitch)	Refer to the clause referring to defective double chain-off thread.		
	Threading	The thread is entangled with the thread guide, or the looper has been incorrectly threaded.	Refer to the threading diagram.	

Trouble	Case (1)	Case(2)	Check and Corrective measures	Page
2. Loper thread breakage	Thread path	Scratches, burrs, rust, etc, on the paw of the throat plate, stitch tongue, looper, looper thread take-up, thread guide, or tension discs causes friction.	Remove such scratches, burrs, etc. and carry out thread path finishing. Replace loopers or other components which have been deformed, causing thread breakage.	
	Adjustment of the looper thread take-up	The looper thread take-up or thread guide has been improperly positioned, causing excessive thread tension.	Refer to the pertinent Standard Adjustment.	62
	Thread tension	The looper thread tension is too high.	Reduce the tension while checking the tension balance other looper thread.	
	Thread	The thread is weak because of its poor quality.	Replace the thread by one with good quality.	
	Position of the thread guides	The upper looper thread guide is too high, and the thread taking balance is disturbed, resulting in the thread breakage.	Refer to the pertinent Standard Adjustment.	62
	Double chain looper avoid (only for double chain stitch)	The double chain looper strikes the needle at the back, causing the thread breakage.	Correct the longitudinal motion of the double chain looper so as not to cause the looper to strike the needle.	20
	Needle heat	The needle gets hot, and the looper thread breaks when it comes in contact with the hot needle at the time of needle stop.	Refer to the clause relating to the needle heat causing needle thread breakage.	
3. Needle breakage	Needle entry	The needle entry has not been correctly adjusted, and the needle strikes the throat plate or presser foot.	Correct the needle entry.	8
	Upper looper position	The upper looper juts out too much or it is too low.	Refer to the related Standard Adjustment.	18
	Contact with the looper	The needle strikes the looper, resulting in needle breakage.	Re-position the looper so that it does not come in contact with the needle. Adjust the longitudinal motion of the double chain looper for the contact of its back with the needle.	

↓
to the next page

Trouble	Case (1)	Case(2)	Check and Corrective measures	Page
---------	----------	---------	-------------------------------	------

From the previous page

Needle guards	A needle guard has been improperly positioned, causing the needle point to strike it.	Refer to the pertinent Standard Adjustment.	22
Needle No.	The needle is too thin for the materials.	Replace the needle with a thicker one.	
Thread tension	The thread tension is too high.	Reduce the thread tension.	
Height of the feed dog or needle	The feed dog is too high, or the needle is too low, causing the needle to deflect with resultant needle breakage.	Refer to the related Standard Adjustment.	8, 24

4. The needle point is crushed. (Double chain stitch needle)

Needle guard	The needle guard C is too low, or its longitudinal position is not correct.	Increase the height of the needle guard (C). Check the clearance between the needle and needle guard.	22
Contact with the looper	The tilt of the looper is not correct. The longitudinal motion of the looper is not correct.	Check the tilt of the looper. Correct the longitudinal motion of the looper, and increase the clearance between the looper and needle when the looper reaches its most retracted position.	20

5. Overlocking needle thread stitches are skipped.

The lower looper fails to catch needle thread loops.

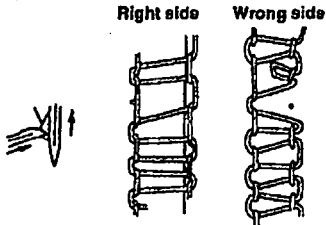

Lower looper	The blade point has defective shape and does not catch needle thread loops.	Replace the lower looper.	
Adjustment of the loopers.	The clearance or the amount of return is not correct.	Refer to the relevant Standard Adjustment.	12
Needle thread presser	The duration in which the presser holds the needle thread is not correct, and unstable loop result.	Refer to the pertinent Standard Adjustment.	
Needle	The needle is bent or improperly oriented. A needle or DC x 1 is used.	Replace the bent needle. Correctly orient and attach the needle. Use a DC x J27 needle for a stretchy thread.	
Needle guards	Incorrect height or clearance prohibits correct guide for the needle. If a needle guard is too high, loops are crushed with consequent stitch skipping.	Refer to the pertinent Standard Adjustment.	22



to the next page

Trouble	Case (1)	Case(2)	Check and Corrective measures	Page
---------	----------	---------	-------------------------------	------

From the previous page

Height of needle	The needle has incorrect height and does not properly pick up loops even if the looper has a correct return.	Refer to the related Standard Adjustment.	8, 12
Needle heat	Stitch skipping occurs before the thread breaks due to needle heat.	Refer to the clause relating to the needle thread breakage due to needle heat.	
Positioning of the needle thread take-up guide and needle thread guide	They are positioned too high, and the needle thread take-up takes too much thread, producing too small loops.	Refer to the pertinent Standard Adjustment.	62
Threading	The thread has been entangled with a thread guide. The reading has not been correctly done.	See the threading diagram.	

6. Lower looper stitches are skipped.

The upper looper does not catch the lower looper thread.

Right side

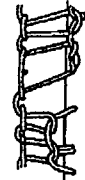

Wrong side

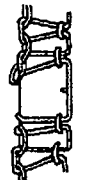

Threading	The thread has been entangled with a thread guide. Threading has not been done correctly.	Refer to the threading diagram.	
Upper looper	The blade point has a bad shape, and fails to catch the loops.	Replace the upper looper with badly deformed blade point.	
Lower looper	The clearance between the needle and the back of lower looper are not correct.	Replace the lower looper having a deformed tip.	
Adjustment of the loopers	The feed amount of the lower looper, height of the upper looper, or clearance produced at time of crossing of the upper and lower loopers is not correct.	Refer to the relevant Standard Adjustment.	12, 18
Thread amount	Too much lower looper thread is fed, giving slack of thread.	Slightly lower the looper thread take-up (left) (reduction in distance J), or slightly reduce distance I to decrease the amount of thread.	62
		Slightly raise the looper thread take-up (right) (increase in dimension O) to decrease the amount of thread. Lower the lower looper thread guide (increase in distance L), and decrease distance N to reduce the amount of thread.	62

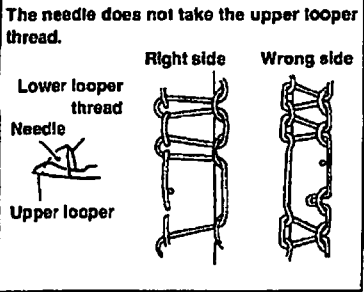
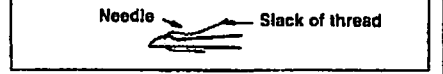
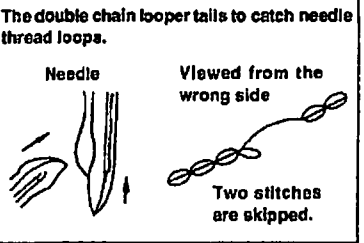
Trouble	Case (1)	Case(2)	Check and Corrective measures	Page
<p>7. Upper looper thread stitches are skipped.</p> <p>The needle does not take the upper looper thread.</p> 	<p>Threading</p> <p>Needle height</p> <p>Needle</p> <p>Adjustment of the upper looper.</p> <p>Amount of thread</p>	<p>The thread has been entangled with a thread guide. Threading has not been done correctly.</p> <p>The needle, if positioned too high or low, may fail to catch the upper looper thread.</p> <p>The needle is bent or crushed, in its point.</p> <p>The height of the blade point is not correct, making the upper looper unable to properly pass the thread to the needle. The clearance between the needle and the back of the upper looper is not correct.</p> <p>Excessive upper looper thread is fed, producing slack of thread.</p> 	<p>See the threading diagram.</p> <p>Refer to the related Standard Adjustment</p> <p>Replace the needle. At this time, be sure to eliminate the cause for such needle bend or needle point crush.</p> <p>Refer to the relevant Standard Adjustment.</p> <p>Slightly lower the looper thread take-up (left) (reduction in distance J), or slightly reduce distance I to decrease the amount of thread. Make the upper looper thread guide (right) shorter decrease in distance K), to reduce the amount of thread.</p> <p>Slightly raise the looper thread take-up (right) (increase in dimension D) to decrease the amount of thread.</p> <p>If the thread tension is not enough, increase it.</p>	<p>8</p> <p>8, 18</p> <p>62</p> <p>62</p>
<p>8. Double chain stitches are skipped.</p> <p>The double chain looper fails to catch needle thread loops.</p> 	<p>Needle height</p> <p>Needle</p> <p>Double chain looper</p>	<p>If the needle is not correct, stitch skipping occurs even when the return of the chain looper is correct.</p> <p>The needle is bent or attached with wrong orientation. A DC x1 needle is used.</p> <p>The lower part of the blade point has been deformed, and the blade point fails loops.</p>	<p>Refer to the pertinent Standard Adjustment.</p> <p>Replace the bent needle. (Remove the cause for the needle bend.) Correct the orientation of the needle. Use a DC x27 needle (with a better recess configuration).</p> <p>Replace the double chain looper.</p>	

to the next page

Trouble	Case (1)	Case(2)	Check and Corrective measures	Page
---------	----------	---------	-------------------------------	------

From the previous page

Adjustment of looper	Clearance or returning amount is not correct.	Refer to the related Standard Adjustment.	20
Thread tension	The thread tension is too high, preventing formation of good loops.	Reduce the tension. However, be careful not to reduce the tension too much, otherwise unstable loops will result.	
Needle guards	A needle guard is too high, and loops are crushed. The clearance is too big, causing the needle to shake.	Refer to the relevant Standard Adjustment.	22
Needle heat	The thread breaks due to heat generated on the needle, depending on the type of materials, number of piles, and sewing speed.	Use a thinner needle. Reduce the sewing speed. Check the coolant if necessary.	

9. Triangle double chain looper thread stitches are skipped.

The needle fails to catch the double chain looper thread.

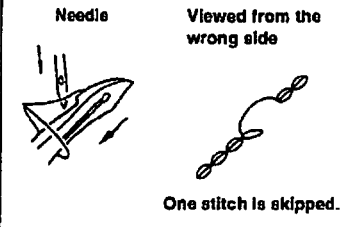

The needle point is crushed.	The needle point has been crushed and got thicker and shorter.	Refer to the clause relating to the needle point crush.	
Double chain looper	The thread hole in the tip has worn, and the looper thread does not reach the needle as shown at right.	Replace the double chain looper.	
Adjustment of looper	Excessive return or longitudinal motion will often cause this stitch skipping.	Refer to the pertinent Standard Adjustment.	20
Thread cam timing	The thread cam timing is too early, causing the looper thread to slack before the needle enters a thread triangle.	Refer to the pertinent Standard Adjustment.	32
Thread tension	The lower thread tension is very low, and the thread is not stretched.	Increase the thread tension a little.	
Threading	The area around the thread cam has threaded erroneously.	Correct the threading.	

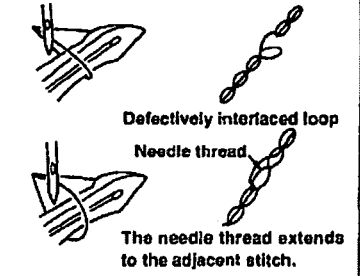
Trouble	Case (1)	Case(2)	Check and Corrective measures	Page
10. Triangle double chain needle thread stitches are skipped.	Double chain looper	The chain looper is too high and too close to the throat plate, or has bad shape.	Correct the height of the chain looper by pushing it down until it cones into contact with the stopper. Replace the chain looper having a bad shape.	20
<p data-bbox="165 386 541 451">The needle falls to catch the needle thread loop on the double chain looper, resulting in the stitch skipping shown below.</p> 	Adjustment of looper	The return is not enough, causing the needle to miss the loop.	Refer to the related Standard Adjustment.	20
	Thread tension	The needle thread tension is too low.	Slightly increase the needle thread tension.	
	Stitch length	The stitch length is as small as 1.5 mm or less.	Slightly increase the stitch length.	
			Adjustment of loopers for producing chain-off thread without materials requires higher accuracy than that with materials.	32
	Needle guard	A needle guard is too high, and catches needle thread loops.	Refer to the related Standard Adjustment.	22
	Double-chain stitch needle thread guide.	The needle thread guide is installed too high, and it fails to tense the thread.	Refer to the related Standard Adjustment.	62
11. Overlocking chain-off thread is bad.	Position of the throat plate	The throat plate has been improperly positioned longitudinally, and chain-off thread gets in between the main feed dog and throat plate, causing defective chain-off thread.	Correctly position the throat plate.	
<p data-bbox="165 889 541 954">Provided that no chain-off trouble occurred when sewing operation was done with materials set on the machine.</p>	Feed dog	The auxiliary feed dog has scratch.	Repair or replace the auxiliary feed dog.	24
		The auxiliary feed dog is too high, and interferes with chain-off thread. The auxiliary feed dog is too low. (Lower than the main feed dog by more than 0.5 mm)	Refer to the pertinent Standard Adjustment.	
	Adjustment of looper	Adjustment of loopers for producing chain-off thread without materials requires higher accuracy.	Refer to the related Standard Adjustment.	12
	Thread tension	The thread tension is too low.	Slightly increase the tension.	
		The needle thread tension is too high, causing damaged balance with other thread tension.	Check whether the needle thread take-up guide or needle thread guide is positioned too high with consequent excessive needle thread tension. And if so, correct it.	62

Trouble	Case (1)	Case(2)	Check and Corrective measures	Page	
12. Problems with double chain stitch chain-off thread.	Adjustment of loopers	Adjustment of the loopers for producing chain-off thread without materials requires higher accuracy.	Refer to the related Standard Adjustment.	20	
	Needle Guard	The needle guard (C) is too high, damaging loops.	Refer to the related Standard Adjustment.	22	
	Position of the throat plate	The needle comes into contact with the front edge of the needle hole in the throat plate.	Correctly position the throat plate.		
		The lateral position of the throat plate with respect to the feed dogs is wrong, causing chain-off to drop in.			
	Throat plate	A dent exists on the flat part between the rear edge of the needle hole and feed dog groove. 	Repair or replace the throat plate, since such dent causes chain-off thread to slip out.		
	Presser foot	The rear pressure foot is indented and not flush with the presser foot sole, so that it cannot hold chain-off thread.	Replace it, or correct it to make it flush with the presser foot sole.		
	Main feed dog	The leading edge of the main feed dog is too sharp and cuts chain-off thread.	Buff the leading edge of the main feed dog.		
	Double hooking	The needle thread is not drawn up fully because of the insufficient return of the double chain looper or wrong threading.	Refer to the related Standard Adjustment for the return of the double chain looper. See the threading diagram for correct threading.		20, 32
		If the feed pitch is too small, the cam timing will be advanced.	Retard the cam timing.		
	Thread tension	The needle is bend or chain-odd thread runs back due to excessive needle thread tension.	Reduce the needle thread tension.		
Both the needle thread and looper thread tension are too low.		Slightly increase the both tensions.			

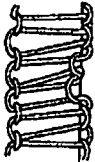
Trouble	Case (1)	Case(2)	Check and Corrective measures	Page	
13. Overlocking needle thread is loose.	Position of the needle thread take-up guide and needle thread guide	They are positioned too high, and the thread take-up draws out excessive needle thread.	Refer to the pertinent Standard Adjustment.	62	
	Thread tension	The thread tension balance has been disturbed.	Refer to the Standard Adjustment for the looper thread take-up components, and increase the tension if necessary.		
	Needle	The needle is too thin for the thread used.	Replace it with a proper one.		
14. Double chain stitch needle thread is loose.	Thread tension	The looper thread tension is too high, and the needle thread tension is too low.	Reduce the looper thread tension to a minimum, and increase the needle thread tension.	32	
	Thread cam	The thread cam draws out an insufficient amount of thread.	Refer to the relevant Standard Adjustment.		
		The thread cam timing is bad.	Refer to the relevant Standard Adjustment.		
	Needle	The needle is too thin for the thread used.	Replace the needle with a proper one.		
	Double-chain stitch needle thread take-up guide	Drawing amount of the needle thread is insufficient.	Refer to the relevant Standard Adjustment.		
15. Uneven overlocking stitches	Looper thread tension	The upper and lower looper thread tensions are not enough.	Slightly increase the upper and lower looper thread tensions.	62	
	Looper thread take-up	The looper thread take-up (left) is too high.	Slightly lower the looper thread take-up (left)		
	Knife width	The knife width is unsuited for the overedging width.	Make the overedging width slightly smaller than that given for the knife width.		
	Thread path	Scratches on the thread path catch thread.	Check the thread path for scratches.		
	Presser foot	The presser foot comes into contact unevenly with the throat plate and lead dogs and tends to meander.	Make the presser foot come into contact with them evenly.		
	The knotting position of the upper and lower looper threads varies as shown below.		Thread dose not come out smoothly.		Make the thread come out smoothly.
			Thread stand		Thread dose not come out smoothly.

Trouble	Case (1)	Case(2)	Check and Corrective measures	Page
16. Uneven double chain stitches	Thread tension	The looper thread tension is not enough.	Slightly increase the tension.	
	Presser foot	The presser foot comes into contact with the throat plate unevenly. The presser foot pressure is not enough.	Make the presser foot come into contact with the throat plate evenly. Increase the presser foot pressure.	
17. The looper thread bulges out	Knife width	The knife width is too small for the overedging width.	Use a knife having width suited to the overedging width.	62
	Looper thread take-up adjustment	The looper thread take-up draws out excessive looper thread.	Decrease the radius of the looper thread take-up (left) (reduction in dimension I). Raise the looper thread take-up (right) (increase in distance O).	
18. Looper thread bite	Knife width	The knife width is too large for the overedging width.	Use a knife having width suited to the overedging width.	62
	Adjustment of the looper thread take-up	The looper thread take-up draws out insufficient amount of looper thread.	Increase the radius of the looper thread take-up (left) (increase dimension I). Lower the looper thread take-up (right) (reduction in distance O).	
19. Knitting position is not correct.	Threading	Re-threading after thread breakage, etc. has been done erroneously.	See the threading diagram.	62
<div style="border: 1px solid black; padding: 5px;"> <p>Right side</p>  <p>Knots are deflected to the upper looper side.</p> </div>	Adjustment of the looper thread take-up	The height of the looper thread take-up (left) is not correct.	Raise the looper thread take-up (left) to increase the amount of upper looper thread, and the knotting position moves toward the lower looper side.	
			The upper looper thread guide (right) is too short.	

Trouble	Case (1)	Case(2)	Check and Corrective measures	Page
20. Uneven material feed	Presser foot pressure	The presser foot pressure is too high.	Reduce the presser foot pressure except for the uneven material feed due to packing.	
	Presser foot	The hinge is too stiff.	Remove the stiffness provided no hinge play is produced.	
		Scratches on or defective finish on the presser foot sole produce friction between the presser foot and materials.	Buff the presser foot sole for good surface finish.	
	Tilt of feed dogs	The front is too high.	Make the front down. However, be sure to align the differential feed dog with the main feed dog.	24
	Height of feed dogs	A different in level exists between the main feed dog and differential feed dog.	Eliminate the difference in level.	24
	Adjustment of differential feed	The differential feed has been improperly adjusted.	Provide differential feed suited to the material.	
21. Puckering (Mainly concerned with double chain stitch)	Needle	The needle is too thick.	Use a thin needle as much as possible.	
	Thread	The thread used is too thick.	Use a thin needle as much as possible.	
	Thread tension	Both the needle thread and looper thread tensions are too high.	Reduce the both thread tensions to a minimum.	
	Throat plate	The throat plate has a large needle hole.	Replace the throat plate with one with a small needle hole.	
	Thread cam timing	The thread cam timing is too late.	Advance the cam timing. Refer to the related Standard Adjustment.	
	Feed dogs	The leading edge of the feed dog teeth has been rounded off.	Replace the feed dog.	
A difference in level exists between the main feed dog and differential feed dog.		Eliminate such difference in level.	24	



to the next page

Trouble	Case (1)	Case(2)	Check and Corrective measures	Page
---------	----------	---------	-------------------------------	------

From the previous page

Presser foot pressure	The presser foot pressure is not high enough, providing poor ironing effect.	Increase the presser foot pressure.	28,28
Differential feed ratio	The differential feed ratio has been set for gathering.	Set it for stretching. When stretching light-weight materials, be careful not to cause the presser foot to contact unevenly with the materials.	
Thread amount	The looper thread amount is not enough, causing excessively tensed stitches.	Bring the thread cam thread guide fully to the front to increase the amount of looper thread.	62

Fully-axen type

Applicable models
MO-6000 Series

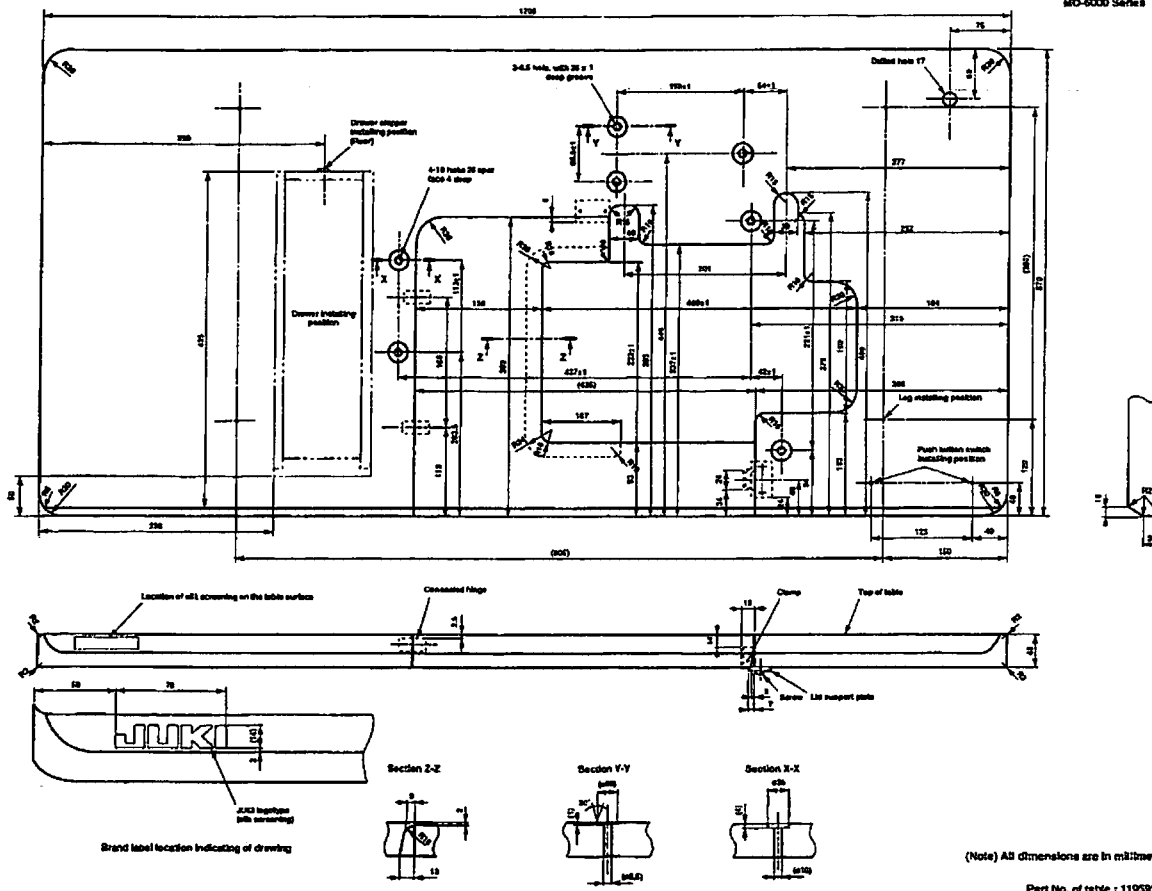

7. DIMENSIONS OF TABLE

Applicable models
MD-6000 Series

(1) Semi-sunken type

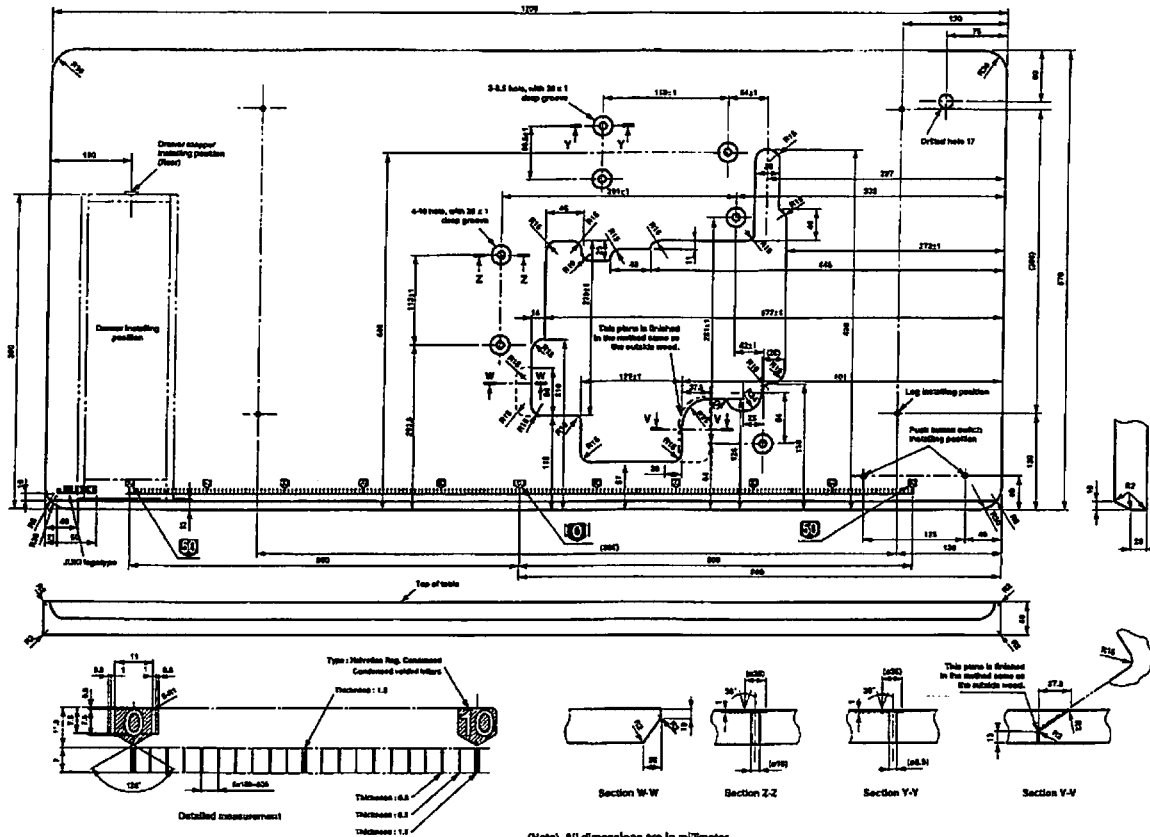

(Note) All dimensions are in millimeter.

Detailed dimensions of section W-W, section Z-Z, section Y-Y and section V-V

Part No. of table : 11959400

JUKI®

JUKI CORPORATION

INTERNATIONAL SALES H.Q.
8-2-1, KOKURYO-CHO,
CHOFU-SHI, TOKYO 182-8655, JAPAN
PHONE : (81)3-3430-4001 to 4005
FAX : (81)3-3430-4909 • 4914 • 4984
TELEX : J22967

Copyright © 2002 JUKI CORPORATION.
All rights reserved throughout the world.

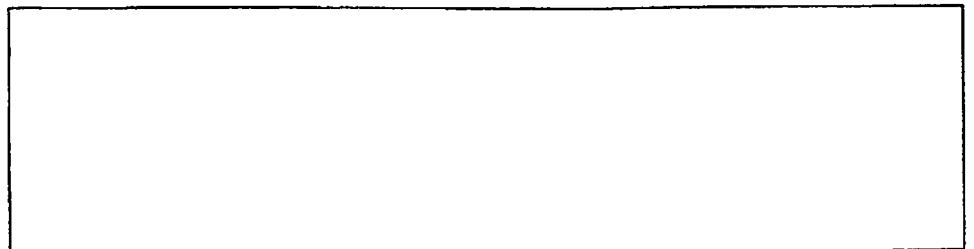

Please do not hesitate to contact our distributors or agents in your area for further information when necessary.
* The description covered in this engineer's manual is subject to change for improvement of the commodity without notice.



7 Fully-suken type

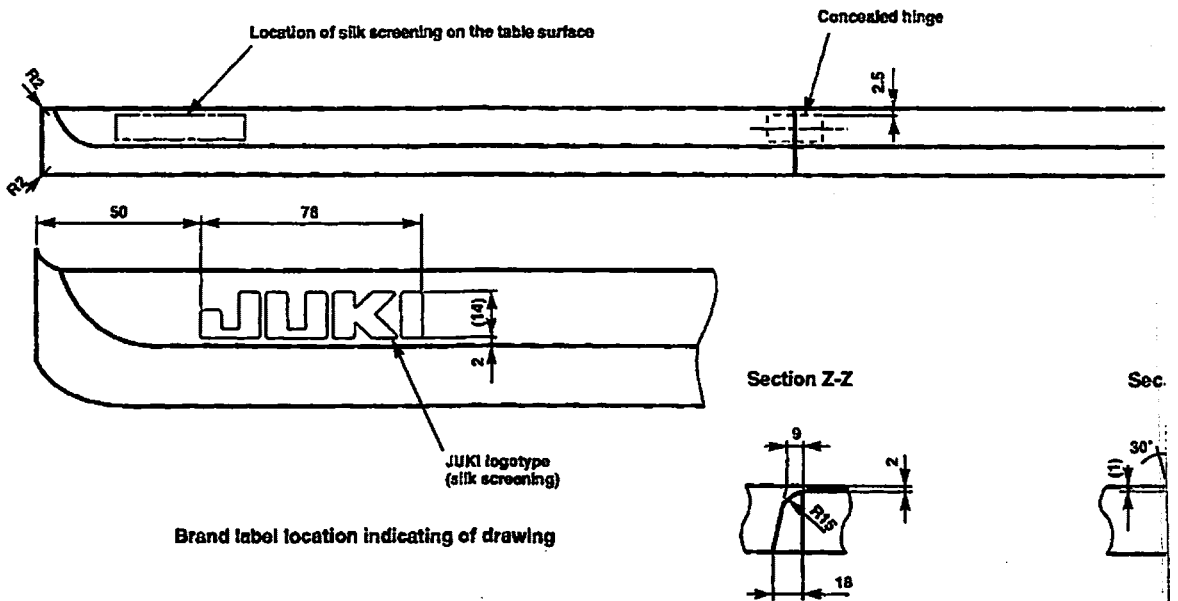
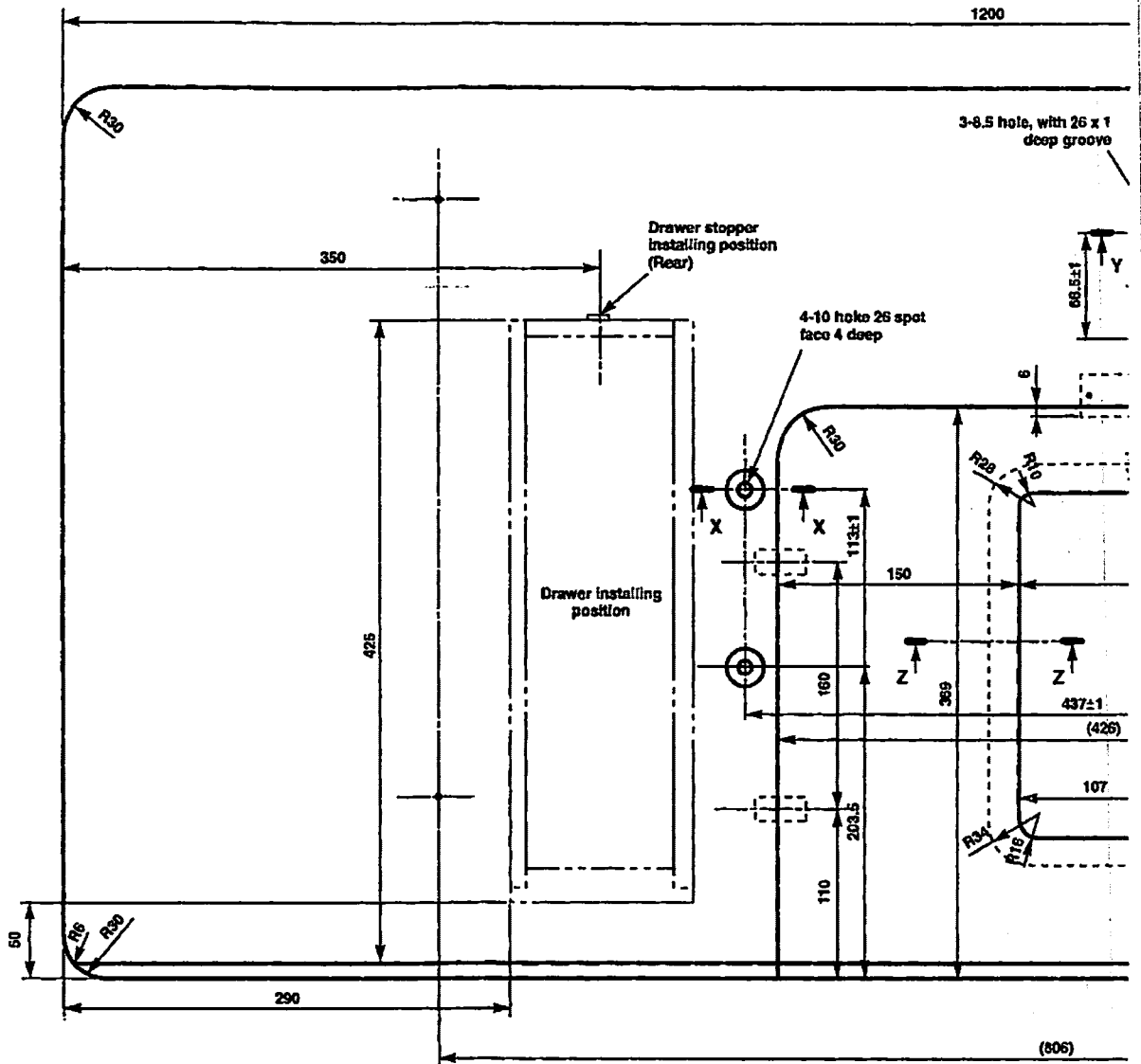

Brand label location indicating of drawing

Applicable models
MO-6000 Series

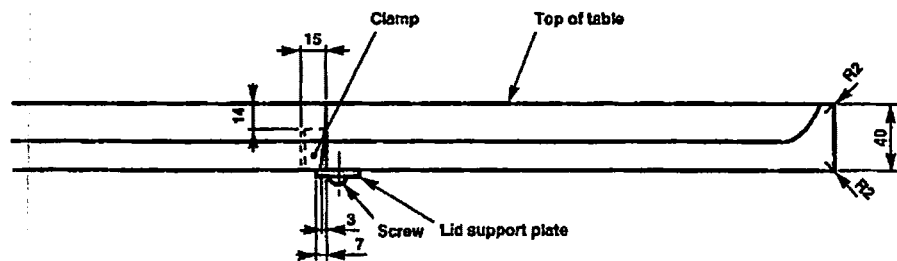
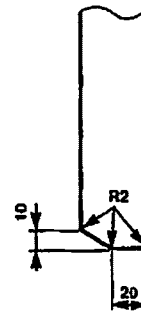
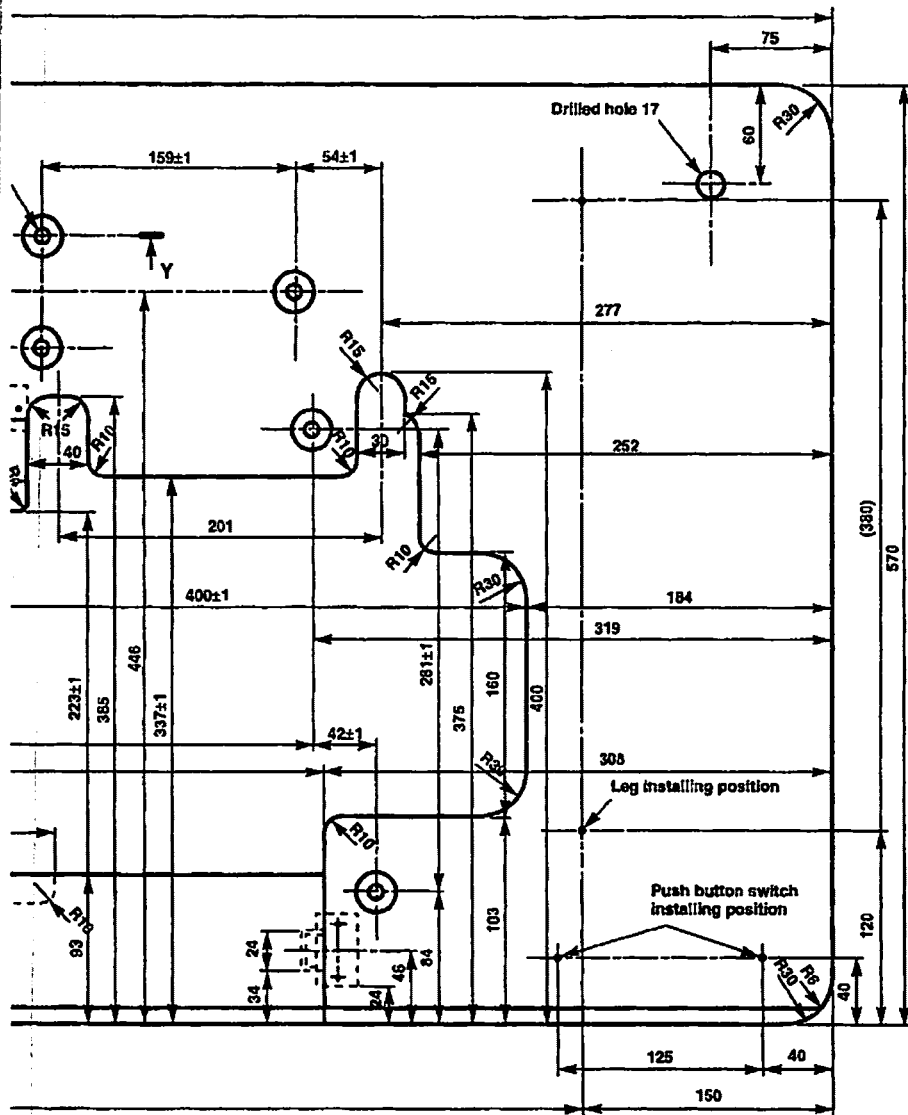

Section Y-Y

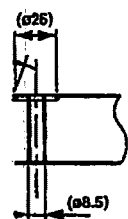

Section X-X

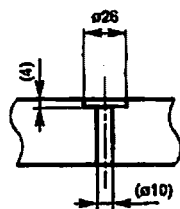

(Note) All dimensions are in millimeter.

Part No. of table : 11959558